

V&V: Model-based testing

Systems Engineering BSc Course

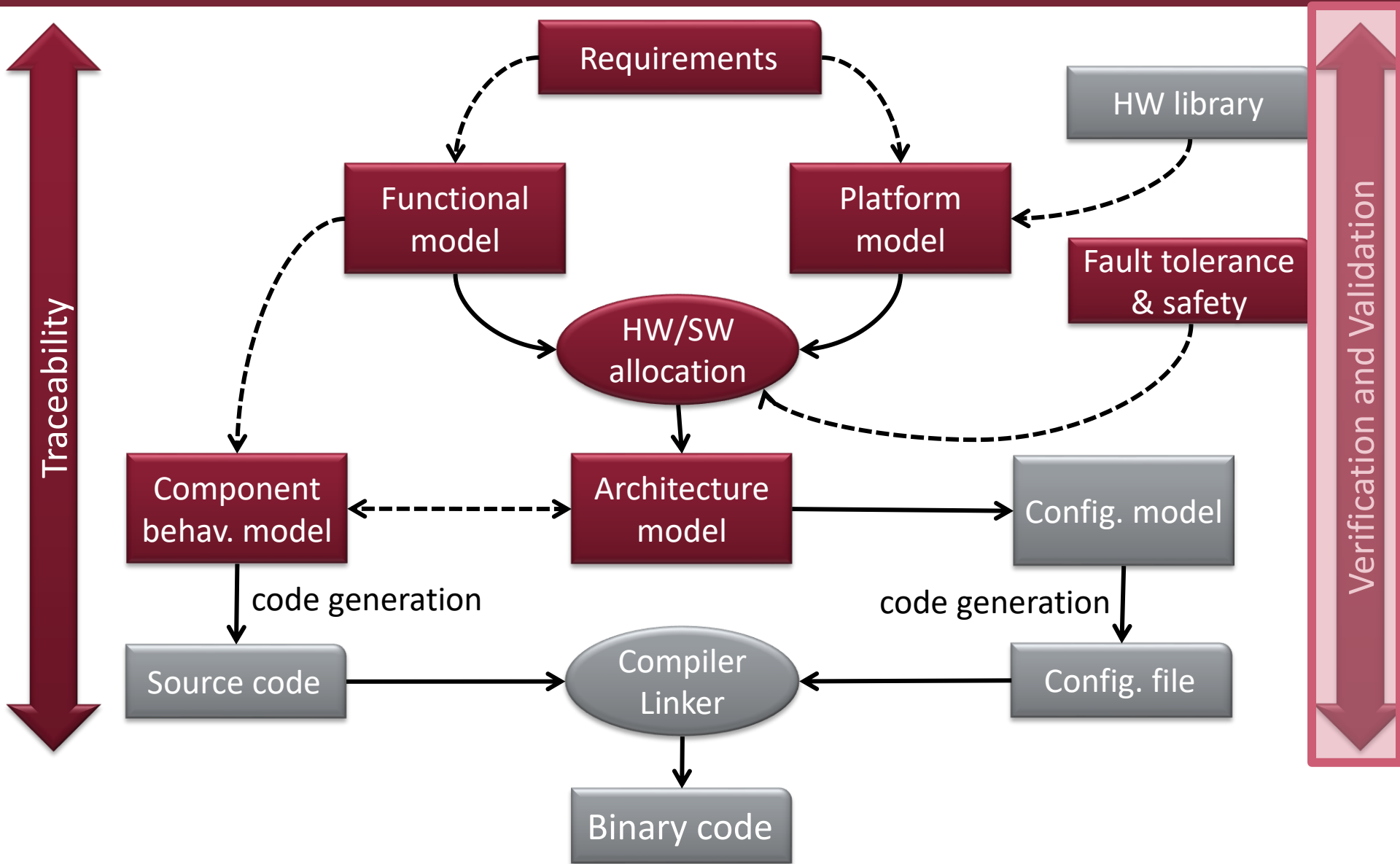

Platform-based systems design



Learning Objectives

Model-based testing

- Recall what is model-based testing
- List how models can be used in testing

Test modeling

- Explain the concepts in UML Testing Profile
- Apply UTP to specify configurations and scenarios in test models

Introduction to MBT

What is model-based testing?

“Testing based on or involving models” [ISTQB]

- Not just test generation
- Not just automatic execution
- Not just for model-driven engineering

Source of definition: ISTQB. “Foundation Level Certified Model-Based Tester Syllabus”, Version 2015

Landscape of MBT goals



Shared understanding

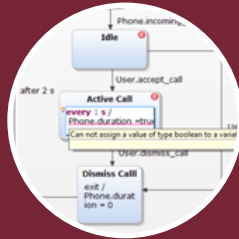

Checking specifications

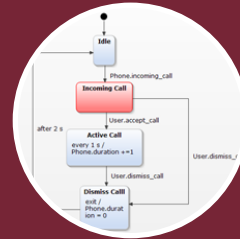

Simulation

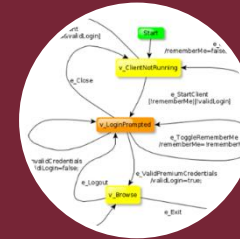

Test data creation



Executable tests



more informal

more formal

Using models in testing (examples)

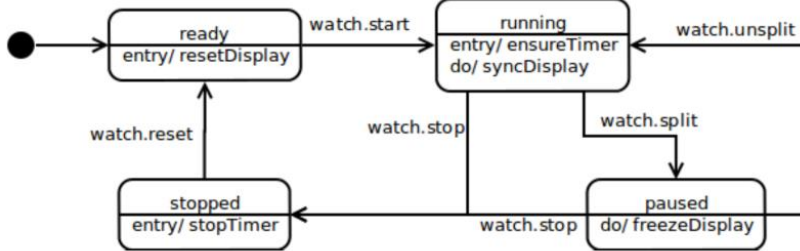

Behavior of SUT

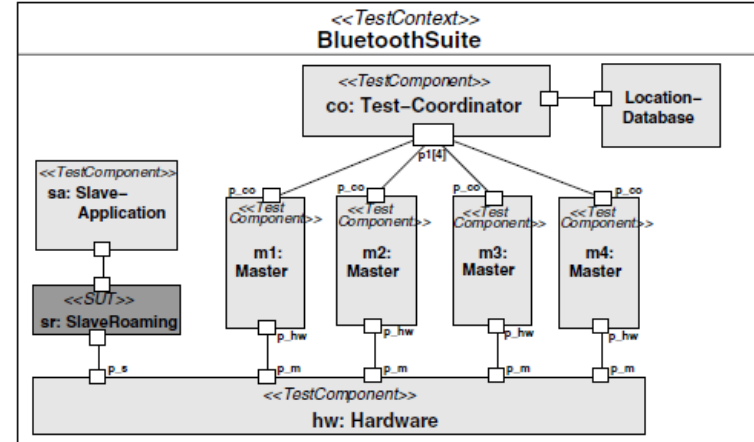

Test configuration

```

timer t;
t.start(5.0);
alt {
  [] i.receive("coffee") {
    Count := Count+1; }
  [] t.timeout { }
}

```

Test sequences

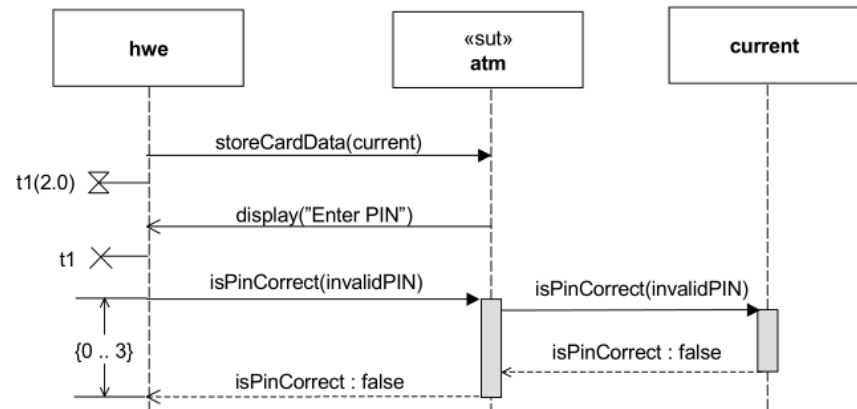

Test sequences

Source: [OMG UTP](http://www.omg.org/UTP)

Benefits of using models

- **Close communication** with stakeholders
 - Understanding of domain and requirements
- **Early testing**: modeling/simulation/generation
- **Higher abstraction level** (manage complexity)
- **Automation** (different artefacts)

Reuse: Development and Test modeling

What if I have existing design models?

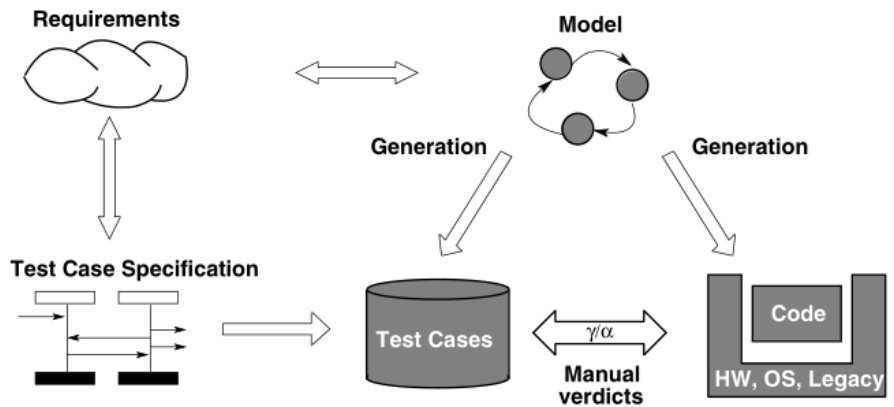

Problem: what do we test here?

Approach: separate dev. and test models

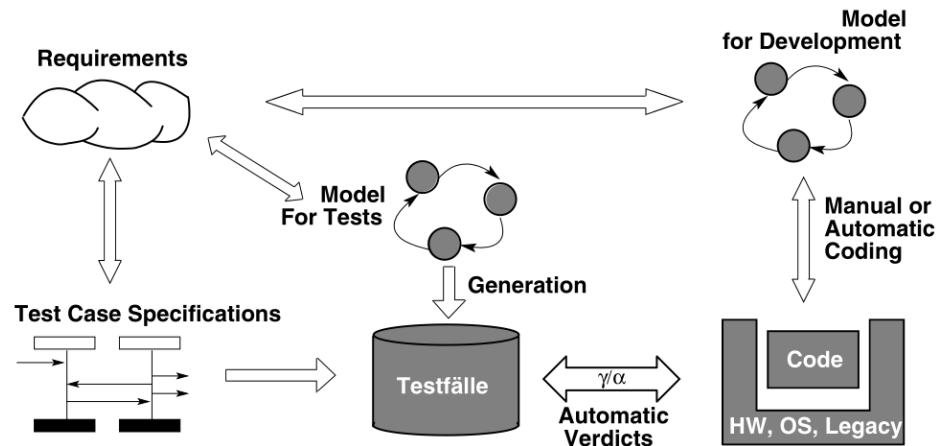

MBT User Survey

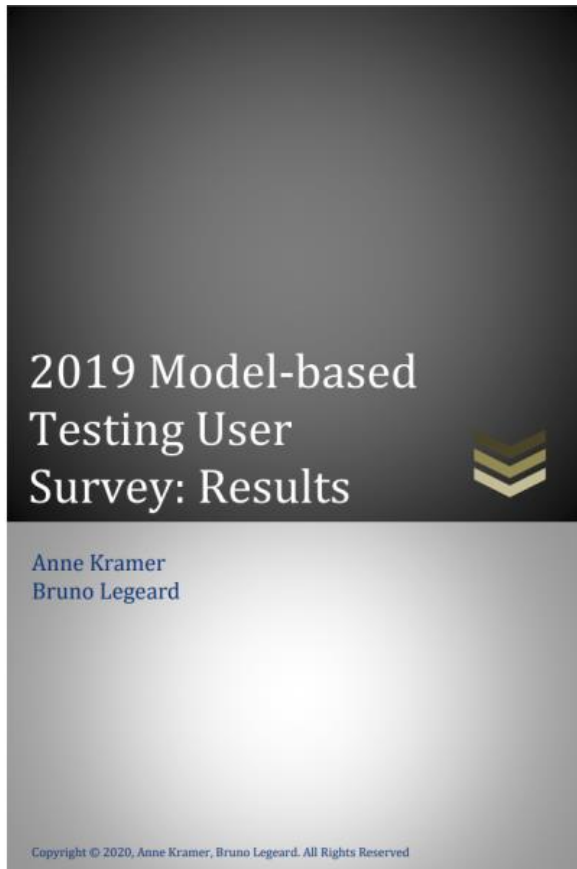

Testing levels

System testing	77,4%
Integration testing	49,5%
Acceptance testing	40,9%
Component testing	31,2%

Generated artifacts

Automated test scripts	84,2%
Manual test cases	56,6%
Test data	39,5%
Others (docs, test suites...)	28,9%

- “approx. 80h needed to become proficient”
- MBT is effective
- Lots of other details!

Source: <https://www.cftl.fr/wp-content/uploads/2020/02/2019-MBT-User-Survey-Results.pdf>

Recap: Tests in finite state machines

- (System modeling VIMIAA00 course)
- Sequence of input events and expected actions
- Model coverage
 - State coverage
 - Transition coverage
- Selecting tests to achieve coverage goals

Note

In the current course we will mainly work on **test modeling** and **not automated test generation** (see MSc courses on that topic)

UML Testing Profile (UTP)

UML Testing Profile (UTP)

- UML profile by OMG
- Capture information for **functional black-box testing** (specification of test artifacts)
 - Mapping rules to TTCN-3, JUnit
- **Language** (notation) and **not a method** (how to test)
- Defines **stereotypes**

Packages (concept groups)

Test Architecture

- Elements and relationship involved in test
- Importing the UML design model of the SUT

Test Data

- Structures and values to be processed in a test

Test Behavior

- Observations and activities during testing

Time Concepts

- Timer (start, stop, read, timeout), TimeZone (synchronized)

Packages (concept groups)

Test Architecture

- Elements and relationship involved in test
- Importing the UML design model of the SUT

Test Data

- Structures and values to be processed in a test

Test Behavior

- Observations and activities during testing

Time Concepts

- Timer (start, stop, read, timeout), TimeZone (synchronized)

Overview of test architecture

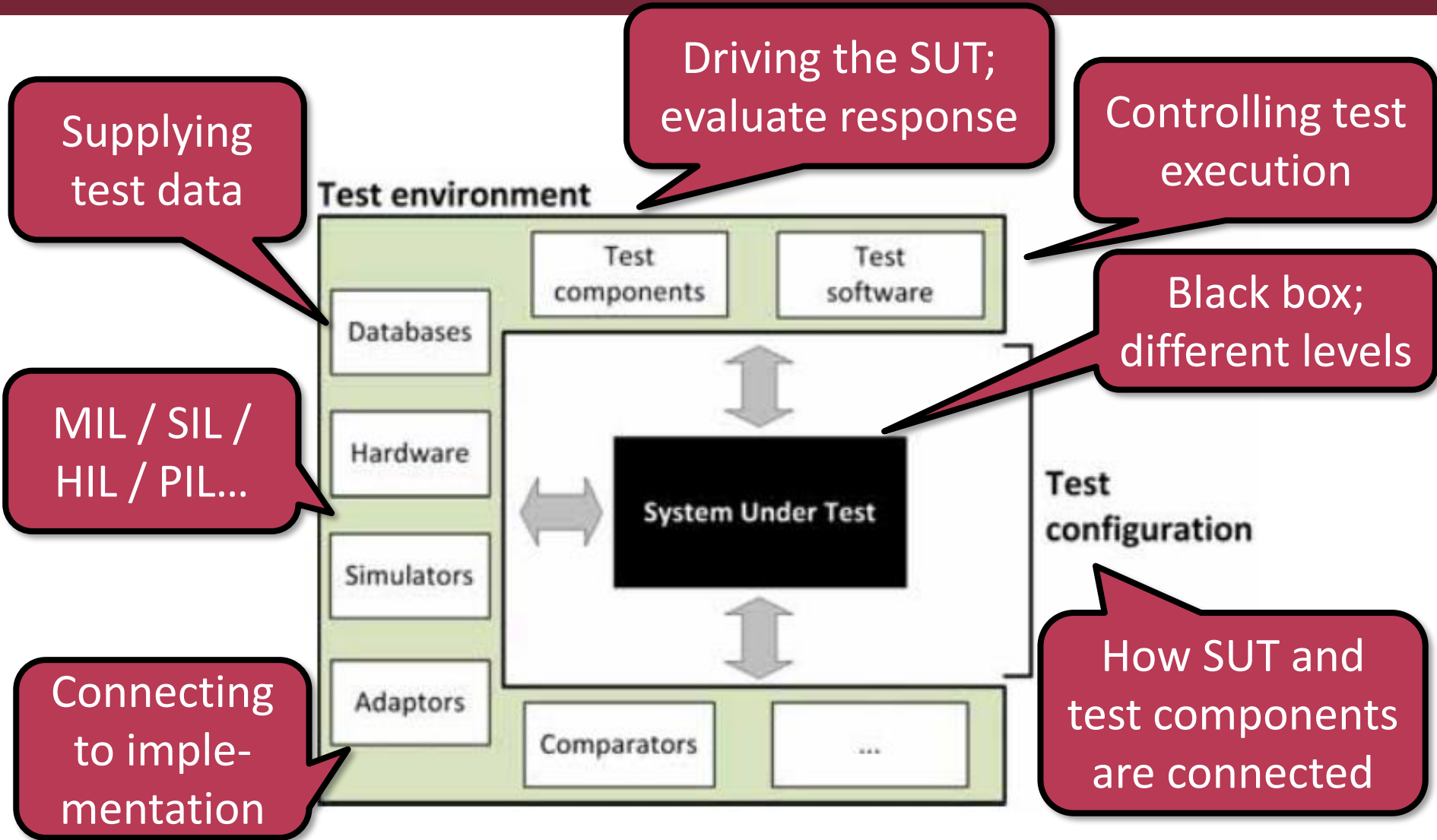

Source: [OMG UTP](#)

UTP Test Architecture package

Identification of main components:

- **SUT**: System Under Test
 - Characterized by interfaces to control and observation
 - System, subsystem, component, class, object
- **Test Component**: part of the test system (e.g., simulator)
 - Realizes the behavior of a test case
- **Test Context**: collaboration of test architecture elements
 - Initial test configuration (test components)
 - Test control (decision on execution, e.g., if a test fails)
- **Scheduler**: controls the execution of test components
 - Creation and destruction of test components
- **Arbiter**: calculation of final test results
 - E.g., threshold on the basis of test component verdicts

Example: UTP Test Architecture

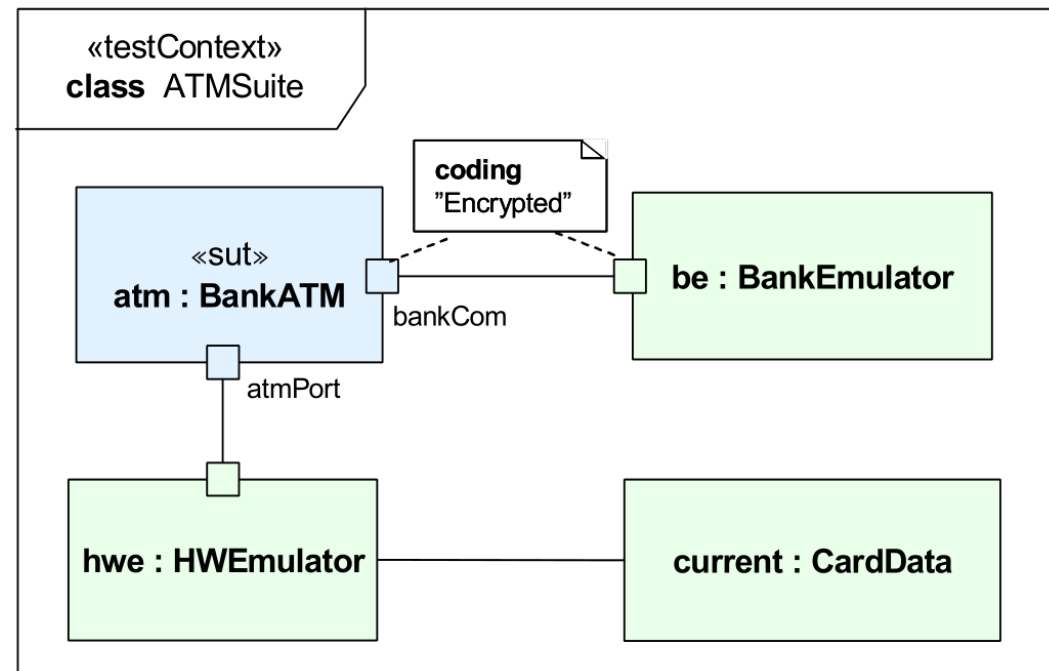
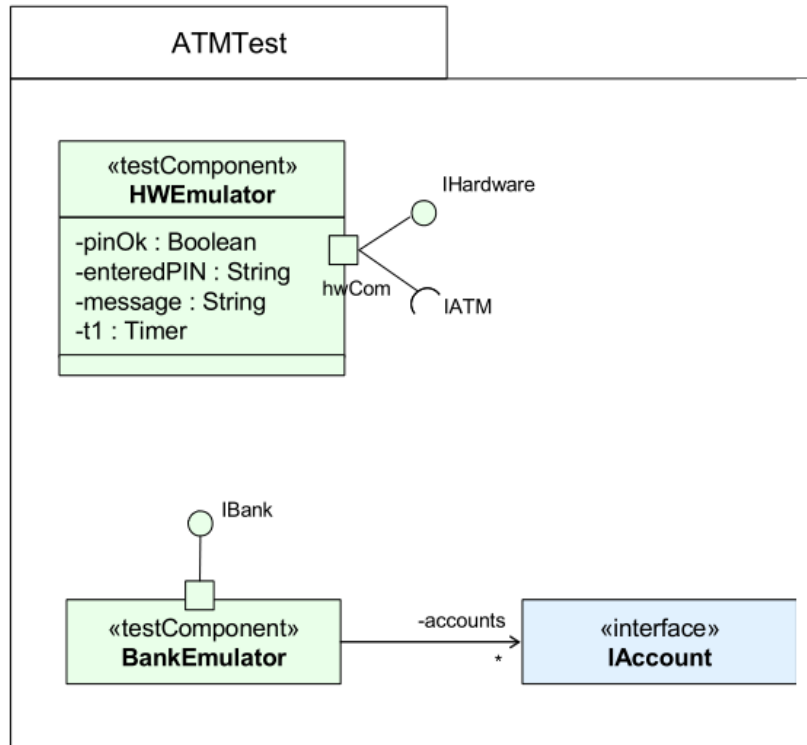

Source: [OMG UTP](#)

Packages (concept groups)

Test Architecture

- Elements and relationship involved in test
- Importing the UML design model of the SUT

Test Data

- Structures and values to be processed in a test

Test Behavior

- Observations and activities during testing

Time Concepts

- Timer (start, stop, read, timeout), TimeZone (synchronized)

UTP Test Data package

Identification of **types and values** for test
(sent and received data)

- Test Parameter (Stimulus and observation)
- Abstract test data
 - **Wildcards** (* or ?)
 - Data Partition: **Equivalence class** for a given type
- Concrete test data
 - Instances with concrete values
 - Data Selector: Retrieving data out of a **data pool**

Example: UTP Test Data

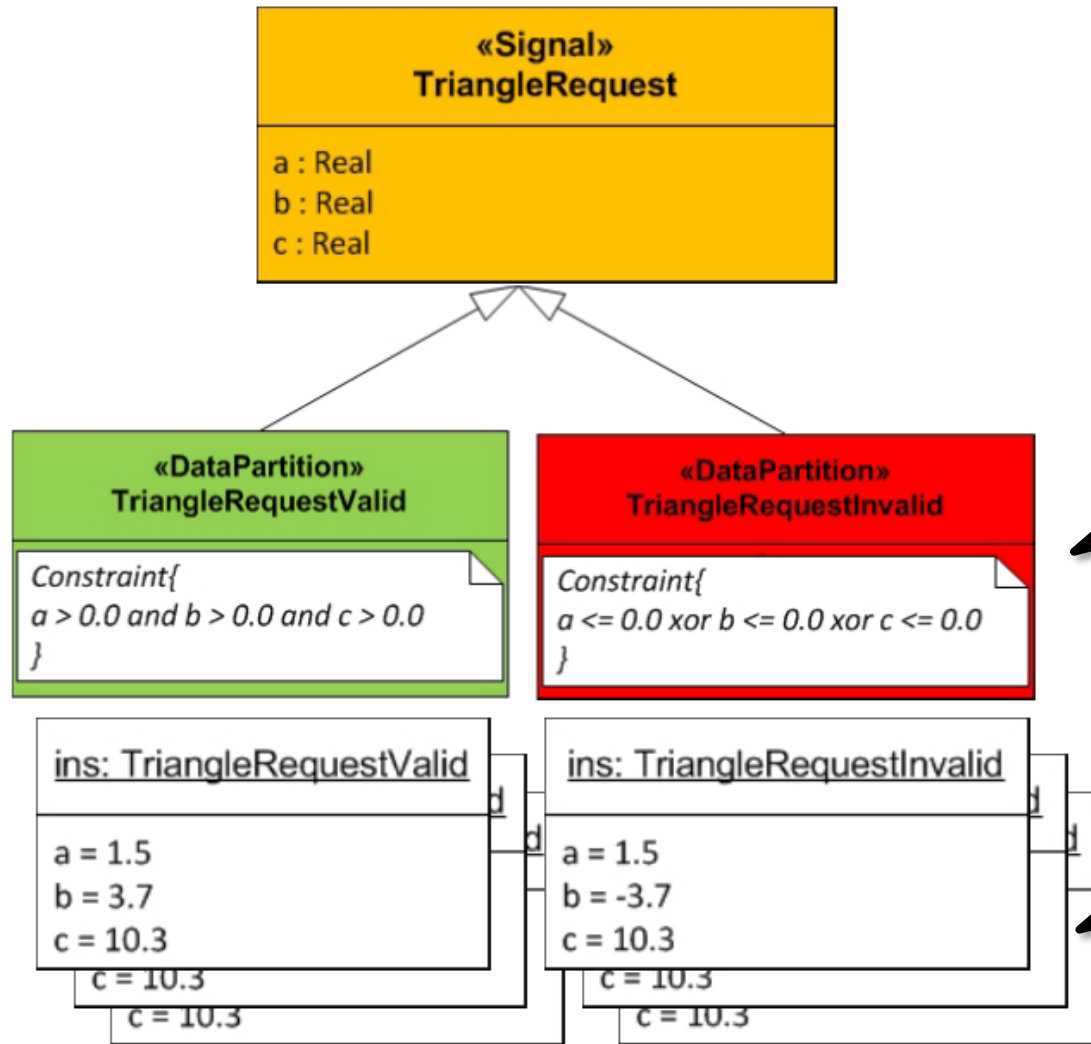

Equivalence classes (abstract)

Concrete values usable in tests

Source: [UML Testing Profile Tutorial](#)

Packages (concept groups)

Test Architecture

- Elements and relationship involved in test
- Importing the UML design model of the SUT

Test Data

- Structures and values to be processed in a test

Test Behavior

- Observations and activities during testing

Time Concepts

- Timer (start, stop, read, timeout), TimeZone (synchronized)

UTP Test Behavior package

- Specification of **default/expected behavior**
- Identification of behavioral elements:
 - **Test Stimulus**: test data sent to SUT
 - **Test Observation**: reactions from the SUT
 - **Verdict**: pass, fail, error, inconclusive values
 - **Actions**: Validation Action (inform Arbiter), Log Action
- **Test Case**: Specifies one case to test the SUT
 - **Test Objective**: named element
 - **Test Trace**: result of test execution
 - Messages exchanged
 - **Verdict**

Example: UTP Test Behavior

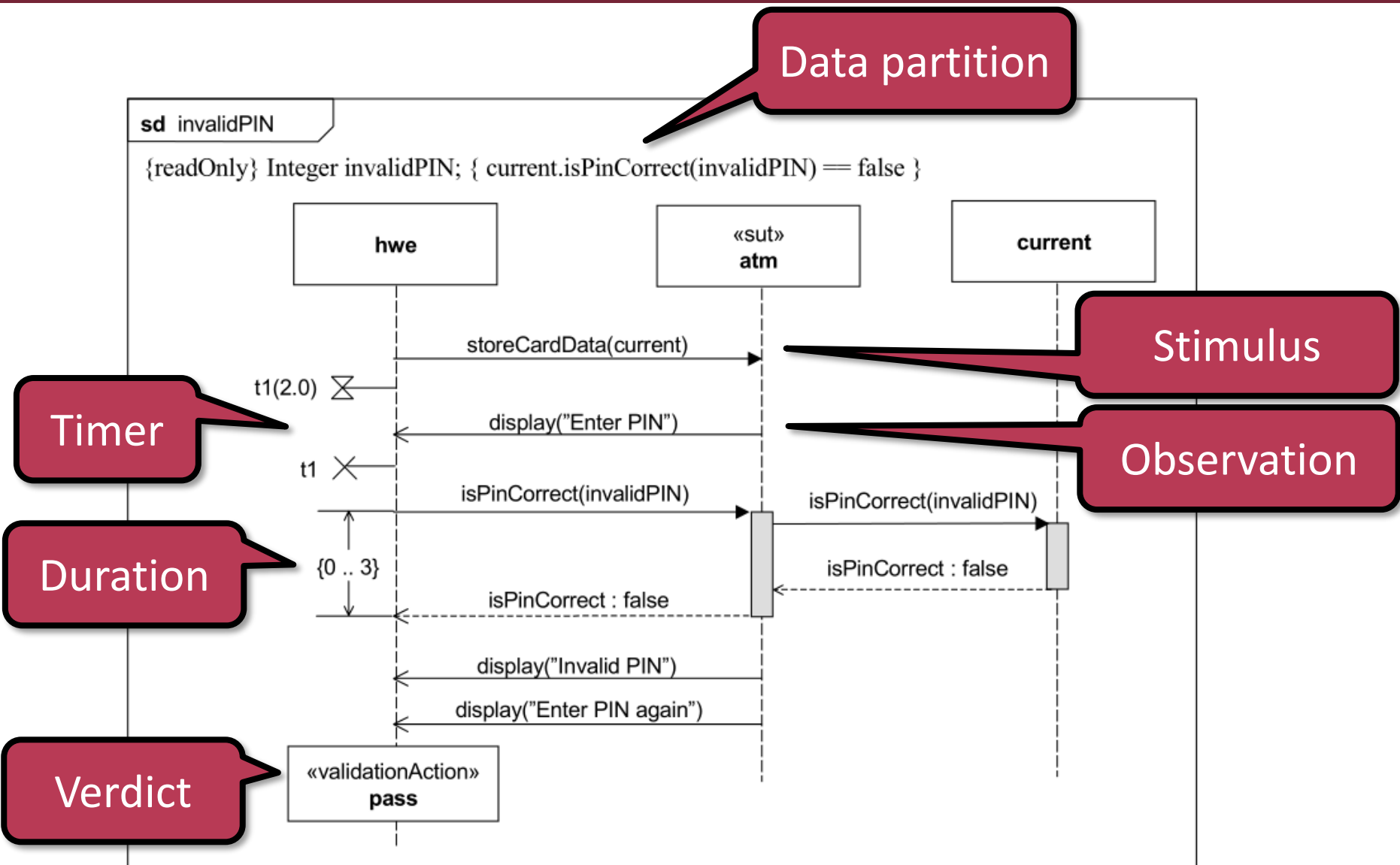

Source: [OMG UTP](#)

Summary of UTP concepts

Test Architecture	Test Behavior	Test Data	Time
SUT	Test objective	Wildcards	Timer
Test components	Test case	Logical partition	Time zone
Test suite	Defaults	Coding rules	
Test configuration	Verdicts		
Test control	Validation action		
Arbiter	Test trace		
Utility part	Log action		

Recommended method for using UTP

1. Define a new package for tests
2. Use interfaces and data types from design model
3. Define test objectives and focus of test
4. Test architecture
 1. Assign SUT to tested component/system
 2. Define test components
 3. Specify test configurations (instances)
5. Test behavior
 1. Design test cases (manually)
 2. Specify defaults and test data

Case study: UTP Test models for Bluetooth roaming

Source: Zhen Ru Dai et al. "[From Design to Test with UML: Applied to a Roaming Algorithm for Bluetooth Devices](#)", TestCom 2004, pp 22-49

About the case study

- **Bluetooth**: short-range wireless communication
- **Standard**: HW (radio, baseband) + SW (protocol)
- **Roaming algorithm**:
 - Master devices connected to LAN
 - Slave devices move, may loose connection to master
 - Roaming:
 - Check periodically the quality of link to master
 - Select a new master if necessary

Components and protocol stack

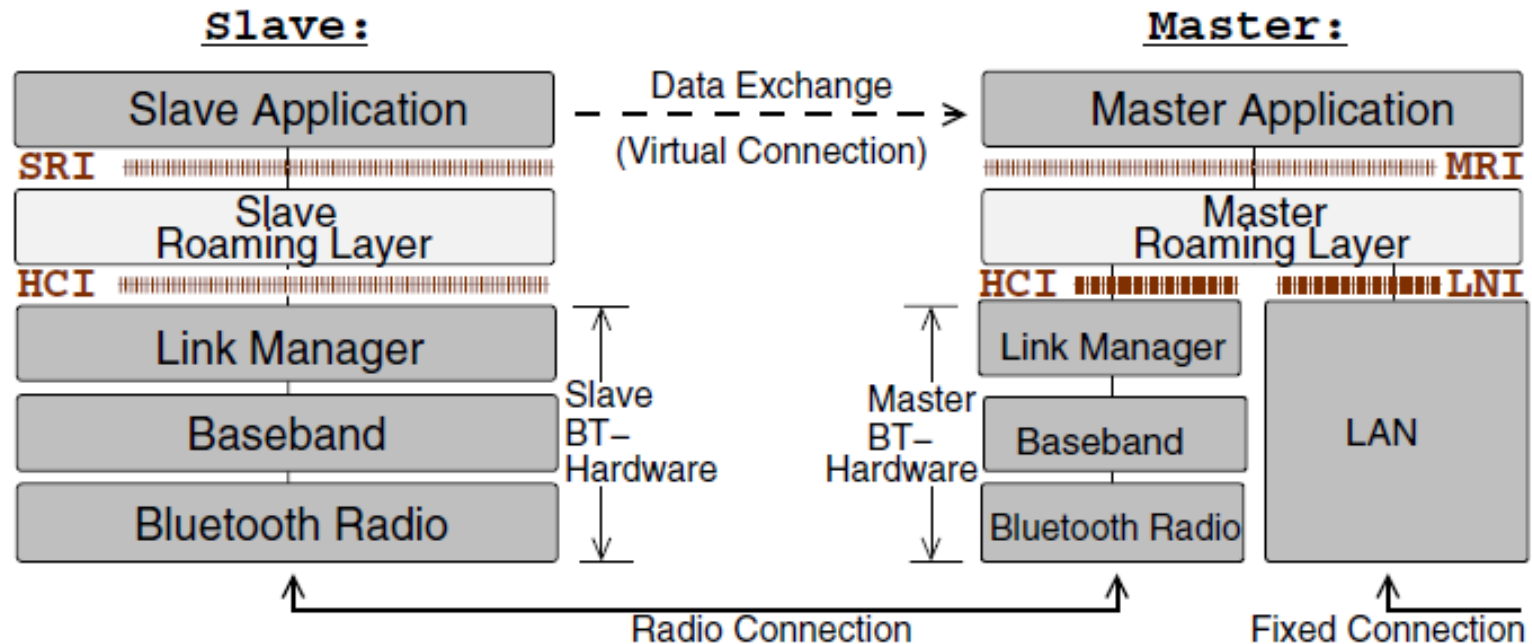

Test objective:

- Slave Roaming Layer functionality
 - Monitoring link quality
 - Connecting to a different master

Possible test levels and setups (1)

Component/module test with software

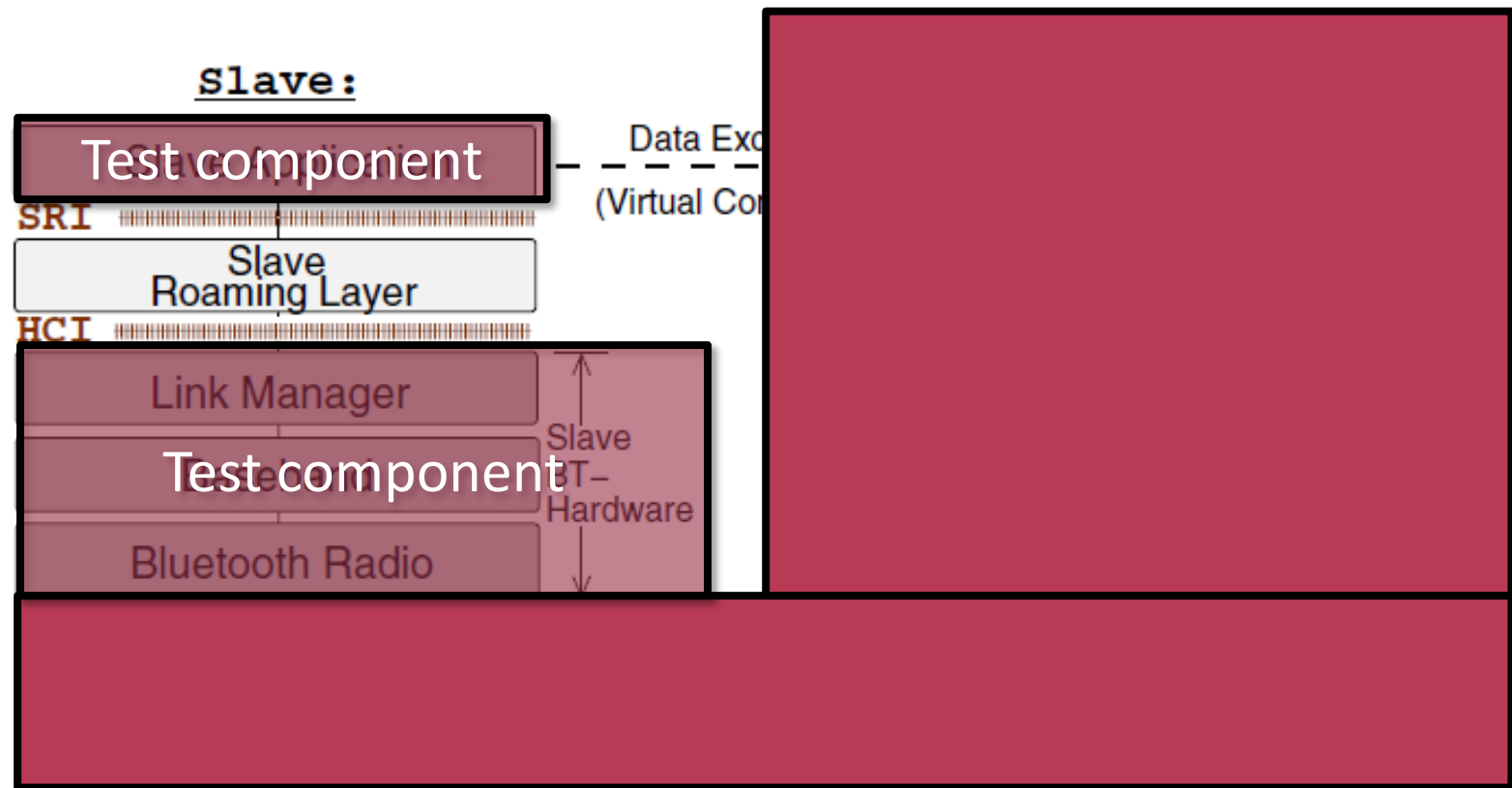

Possible test levels and setups (2)

Integration test with software

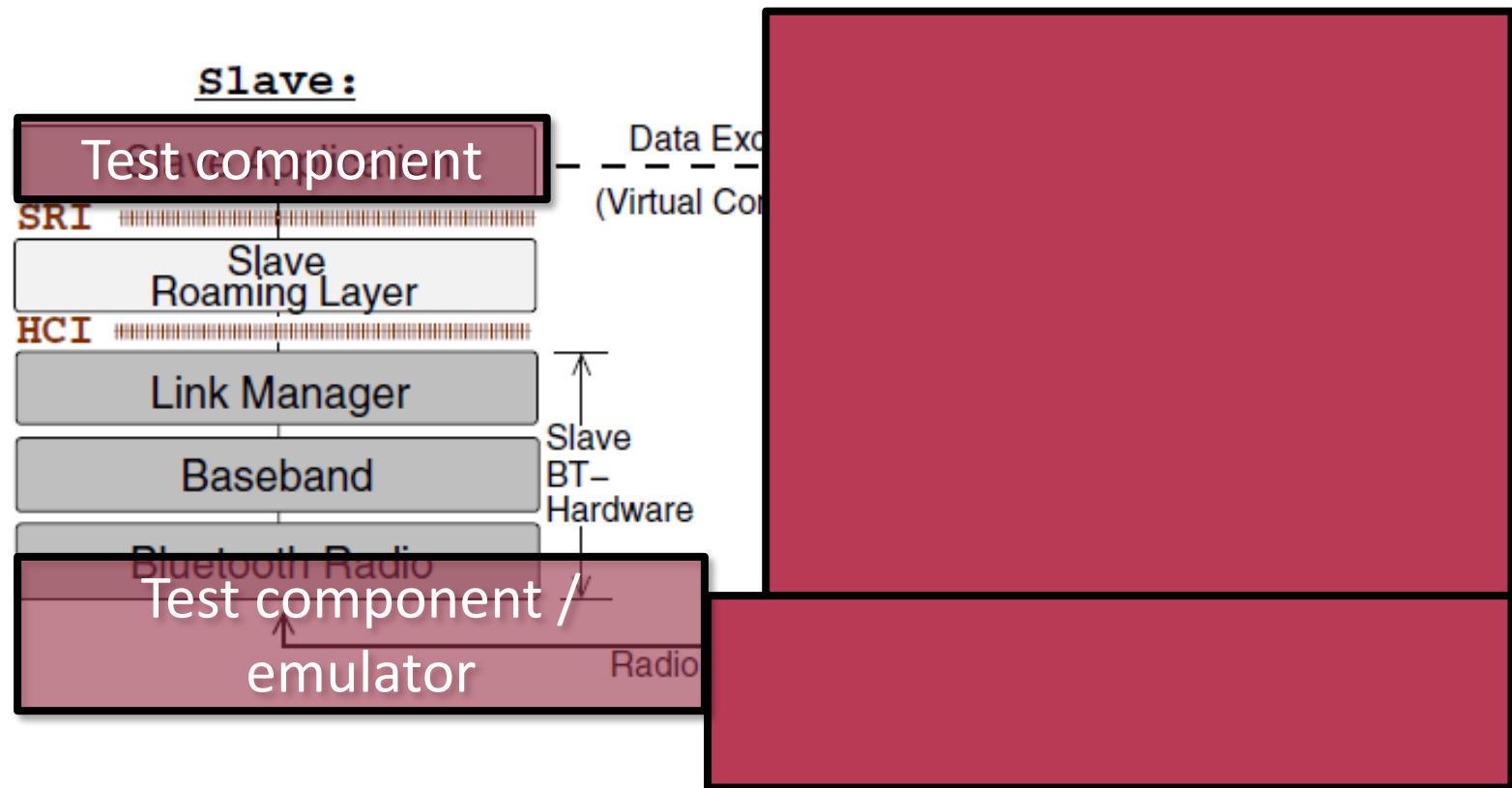

Possible test levels and setups (3)

Integration test with software

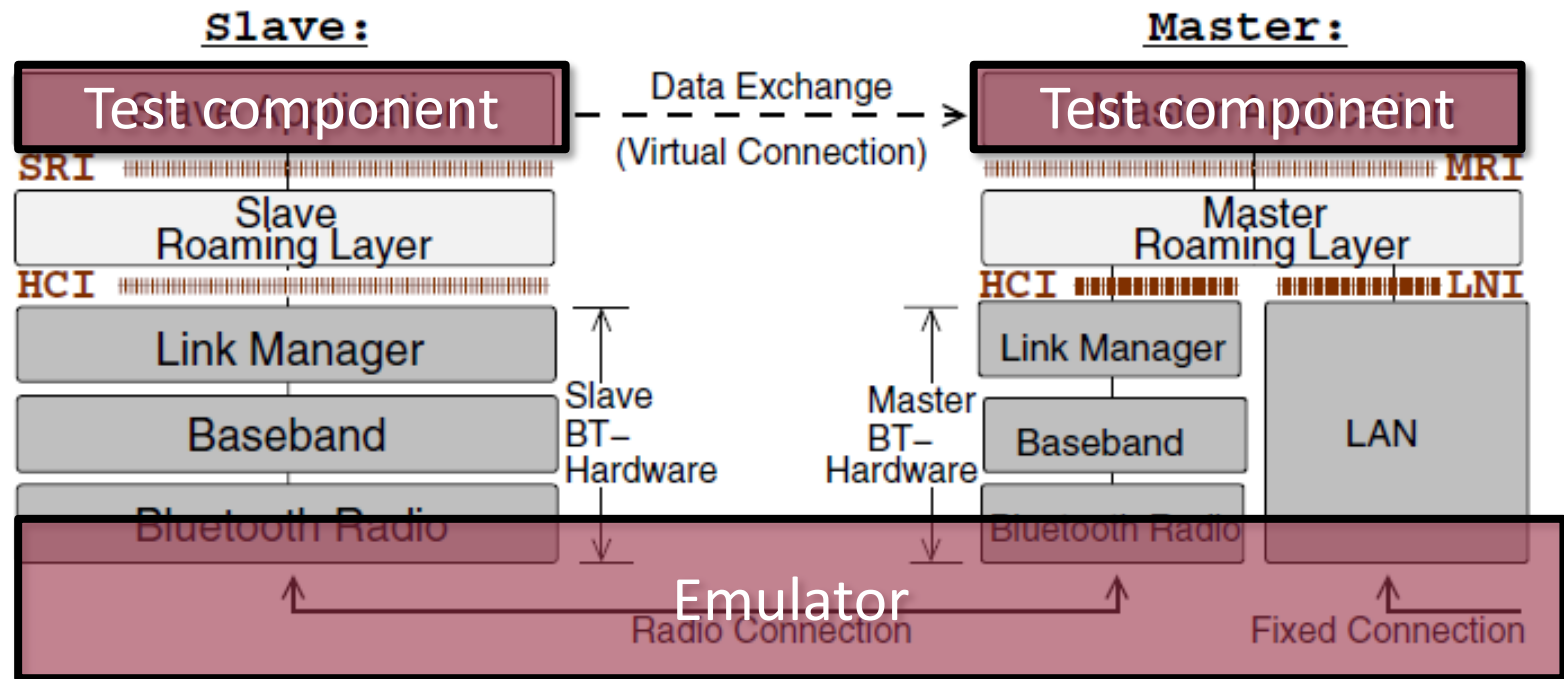

Possible test levels and setups (4)

System test with hardware

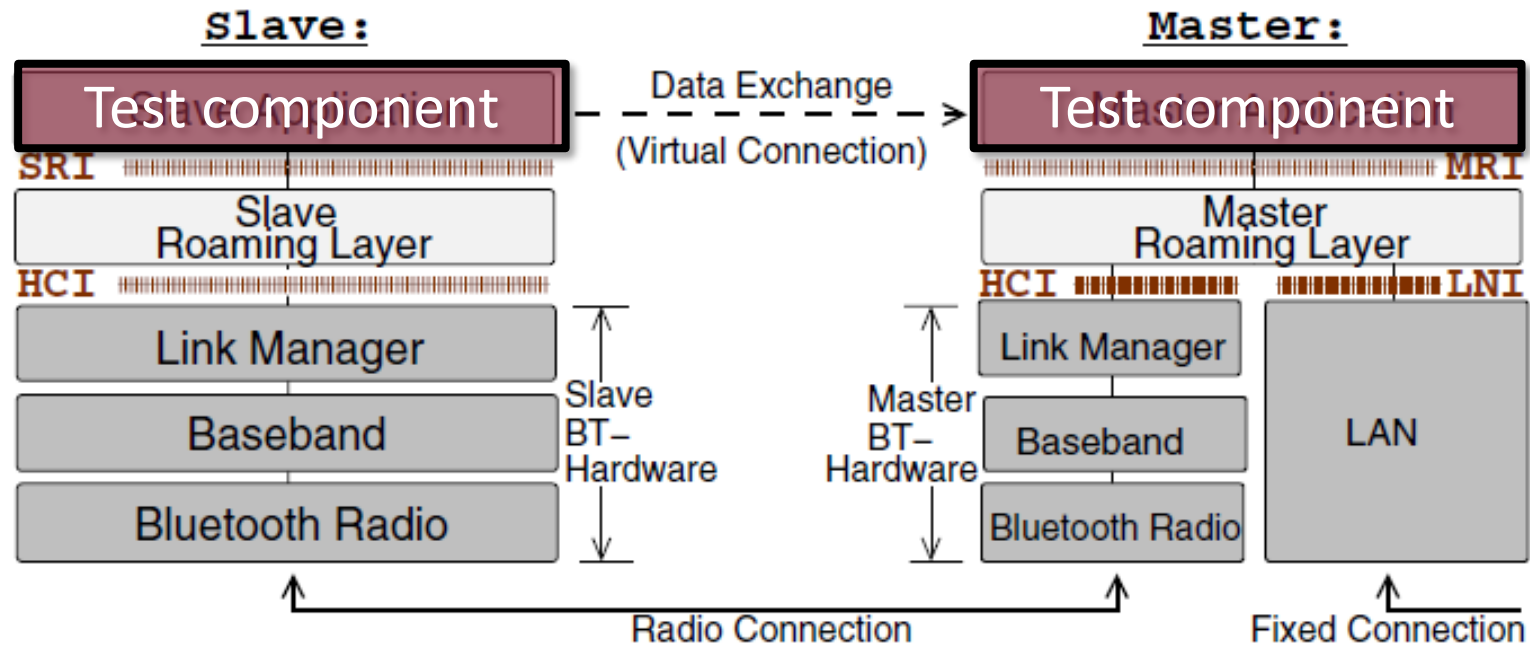

Moving physical devices or wireless test chamber...

Refining test objective

Slave Roaming Layer functionality

1. “Is the Slave Roaming layer able to choose a new master by looking up its roaming list when the connection with its current master gets weak?”
2. “Does the Slave Roaming layer request a connection establishment to the chosen master?”
3. “Does the Slave Roaming layer wait for a connection confirmation of the master when the connection has been established?”
4. “Does the Slave Roaming layer send a warning to the environment, when no master can be found and the roaming list is empty?”

Selected test configuration

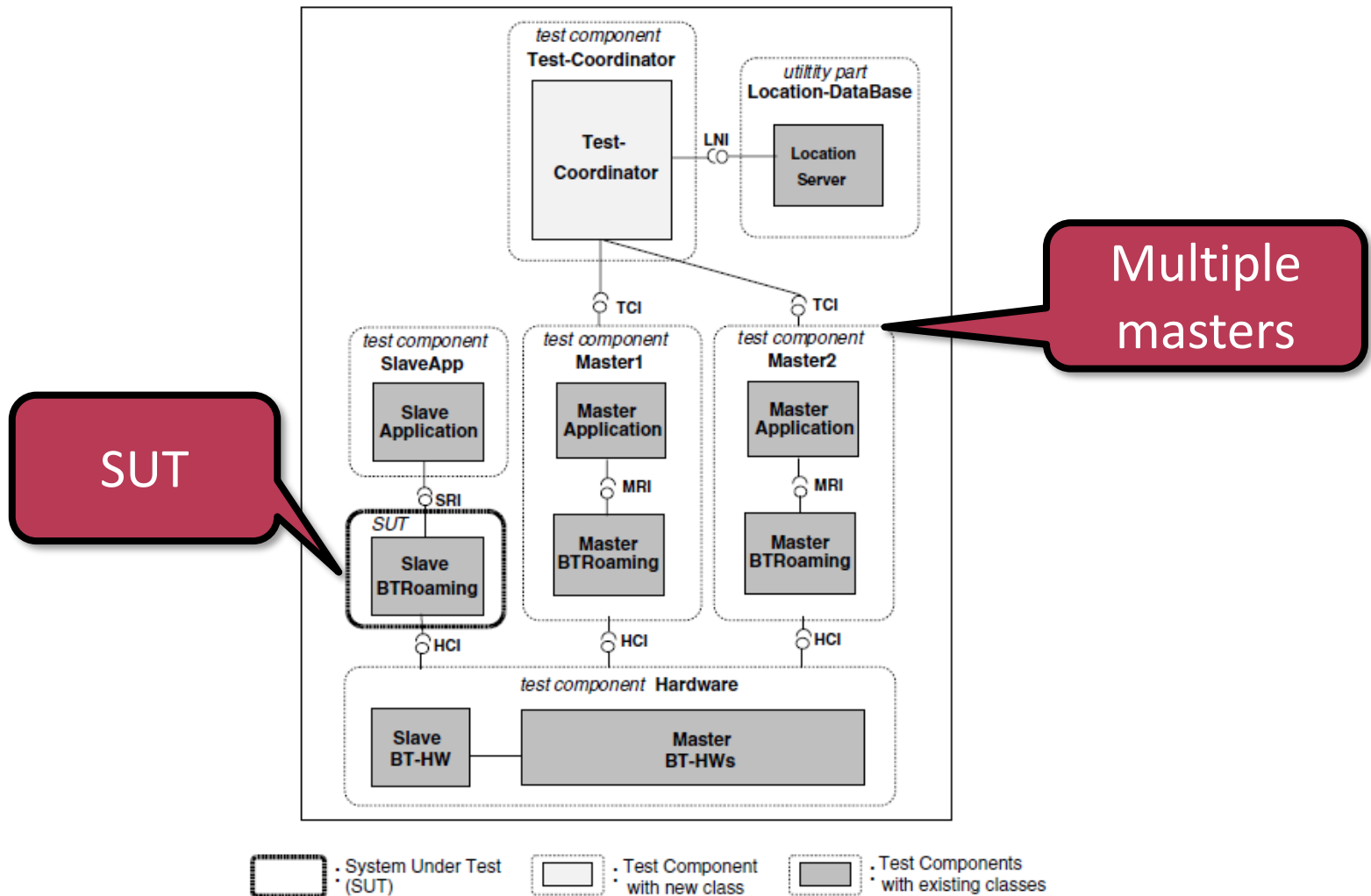

UTP Test architecture: components

Test package

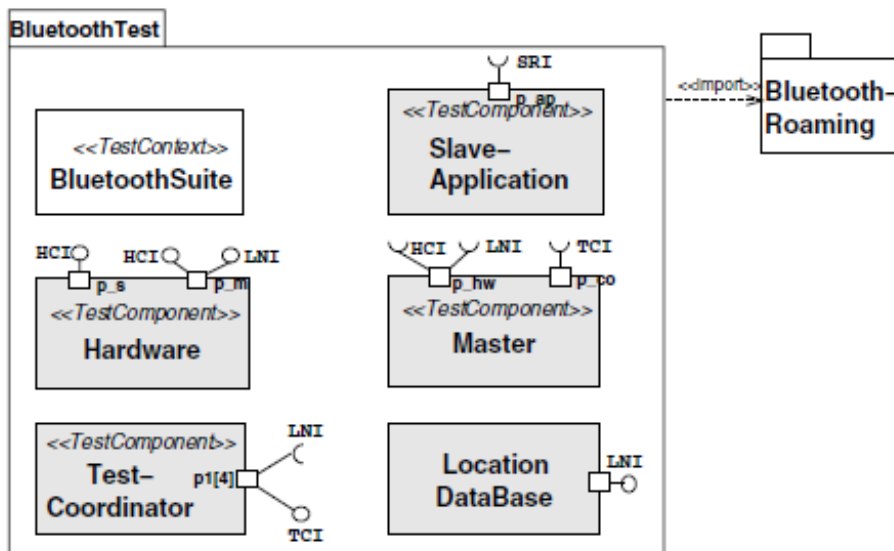

Test context

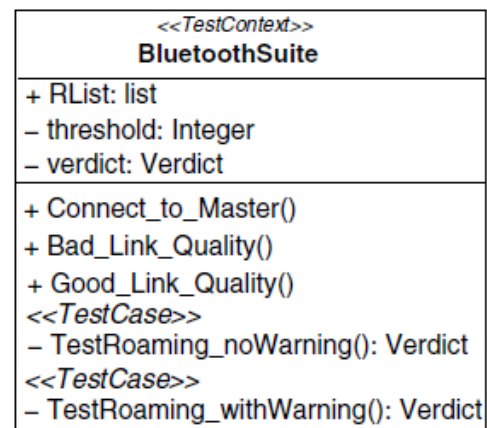

UTP Test architecture: configuration

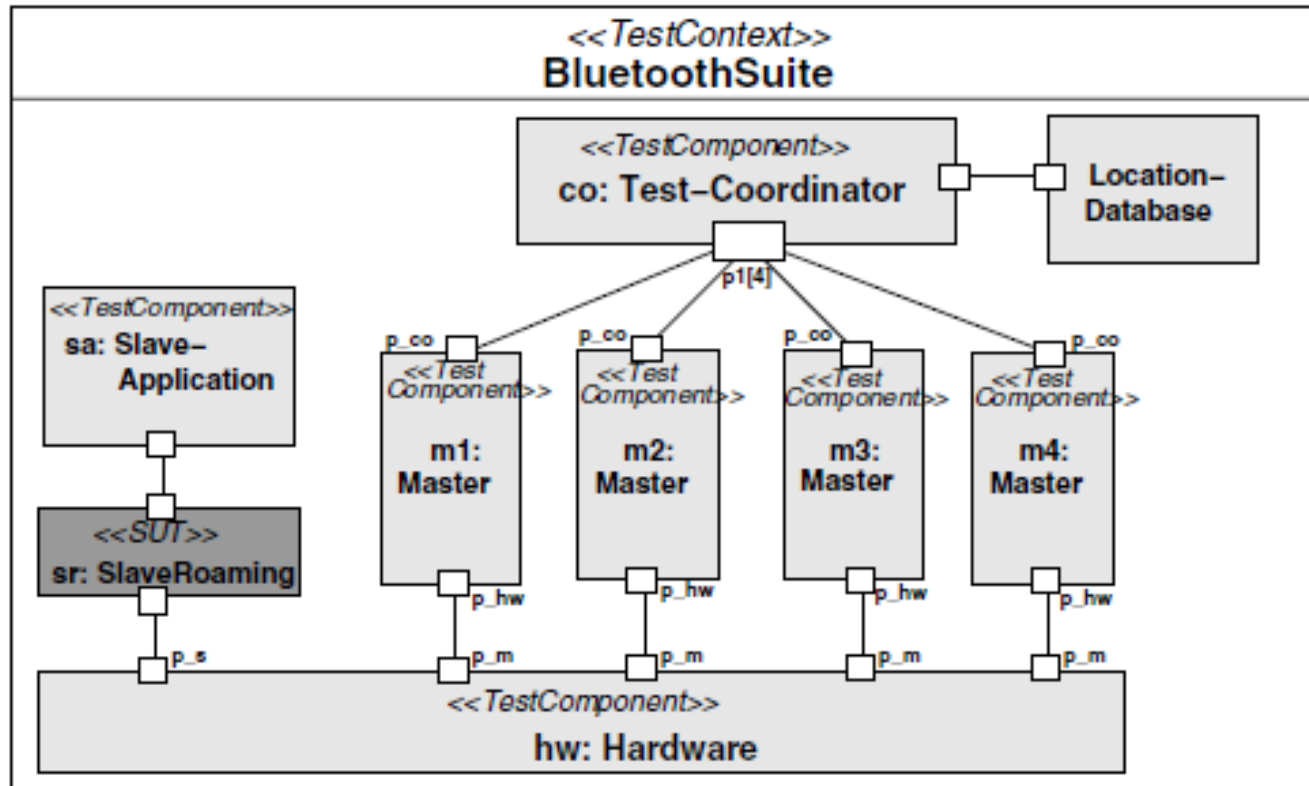

Test configuration

Test behavior

Selecting test scenarios for test objectives

- **Objective:**
 - Choosing new master when the connection with its current master gets weak
- **Scenario 1:**
 - “After the exchange of two data packages, the link quality between Slave and its current master $m1$ becomes bad. The first alternative master in the roaming list $m2$ cannot be reached since the link quality is also weak. Thus, after at most two seconds, a further master $m3$ is chosen from the roaming list and the connection is established successfully.”

Test scenario

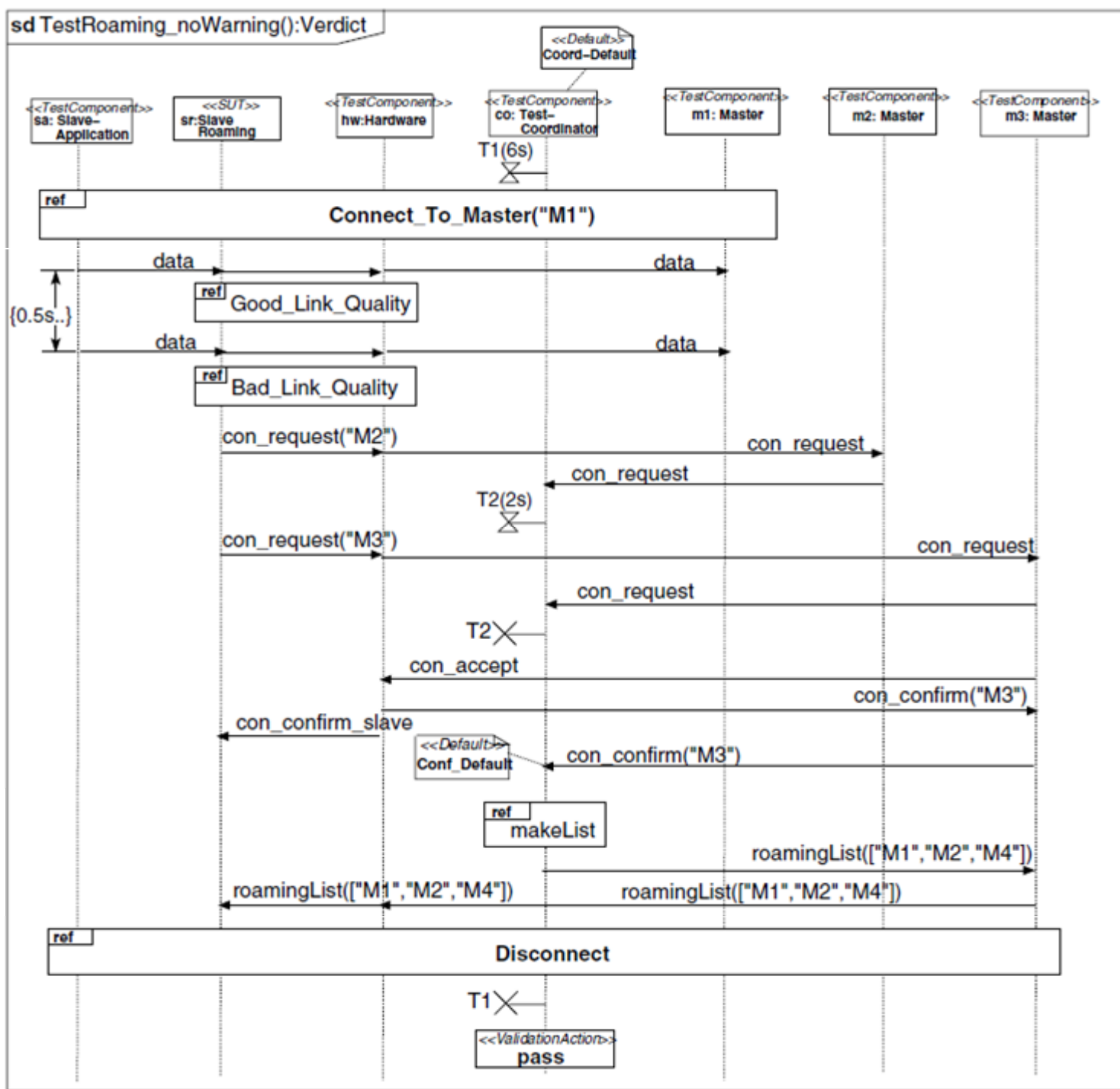

Test scenarios (details)

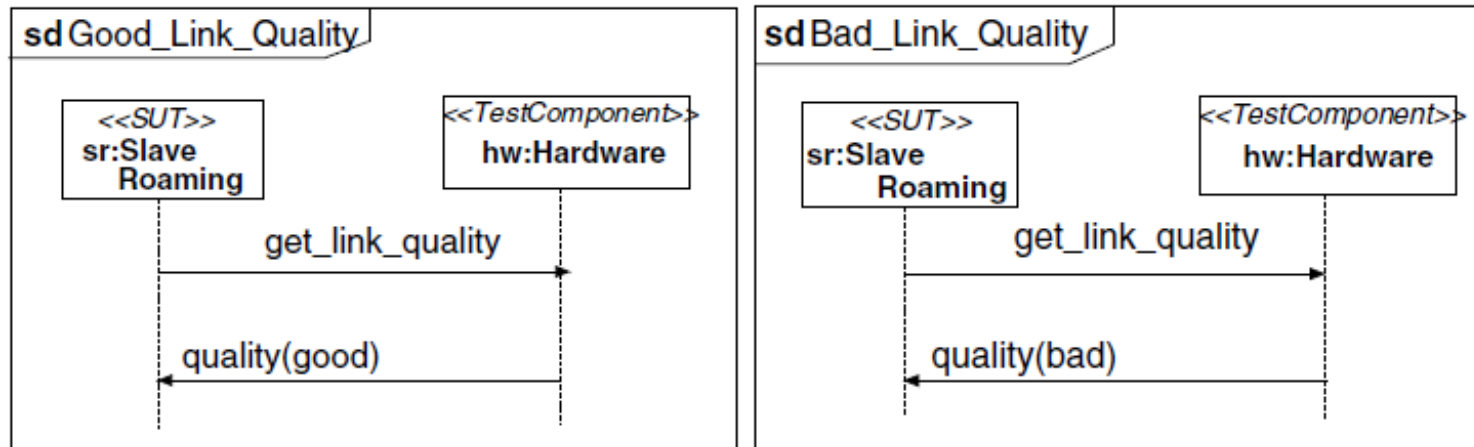

Sequence diagrams

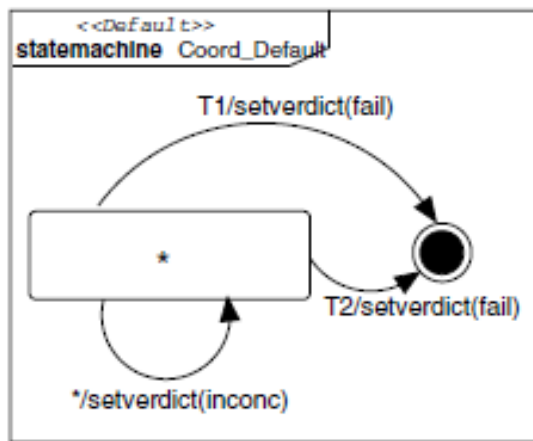

Default behaviors specified to catch the observations that lead to verdicts

- Here: Processing timer events

Summary

What is model-based testing?

“Testing based on or involving models” [ISTQB]

- Not just test generation
- Not just automatic execution
- Not just for model-driven engineering

Source of definition: ISTQB. “Foundation Level Certified Model-Based Tester Syllabus”, Version 2015

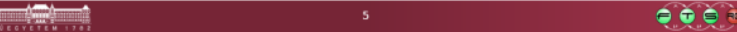

Using models in testing (examples)

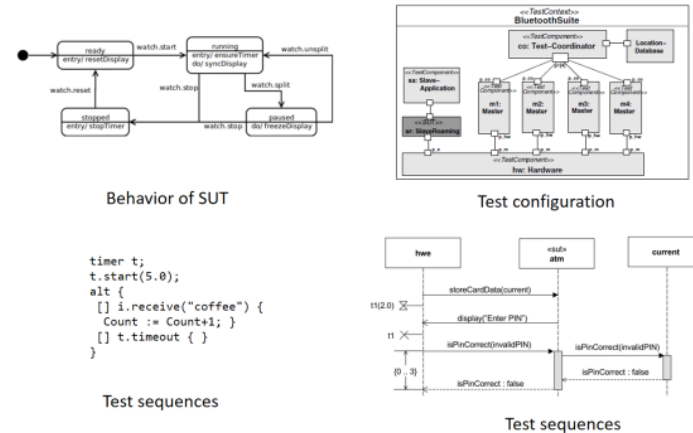

U2TP Test architecture: configuration

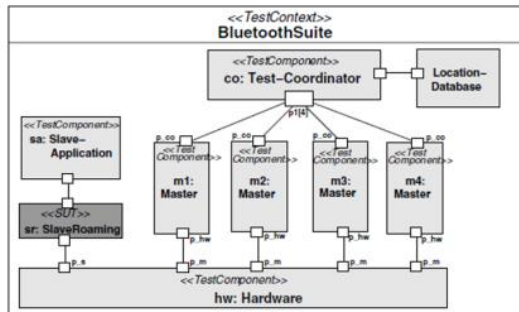

Test configuration



Example: U2TP Test Behavior

