

Basics of Modeltransformation

Varró Dániel
Horváth Ákos

Model Driven Software Development
Lecture 10

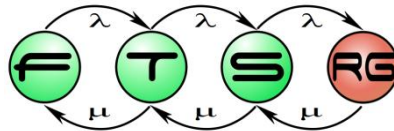

Development Process for Avionics Systems

Unique Development Process (Traditional V-Model)



Avionics Systems Design

- requires a **certification process**
 - DO-178B
- to develop **justified evidence**
 - Certification artifacts
- that the **system is free of flaws**
 - Fulfils the requirements → traceability from requirements to synthesized source code

Certified tool → Fault-free output

Development Process for Avionics Systems

Traditional V-Model



Model-Driven Engineering

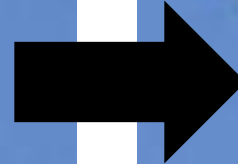
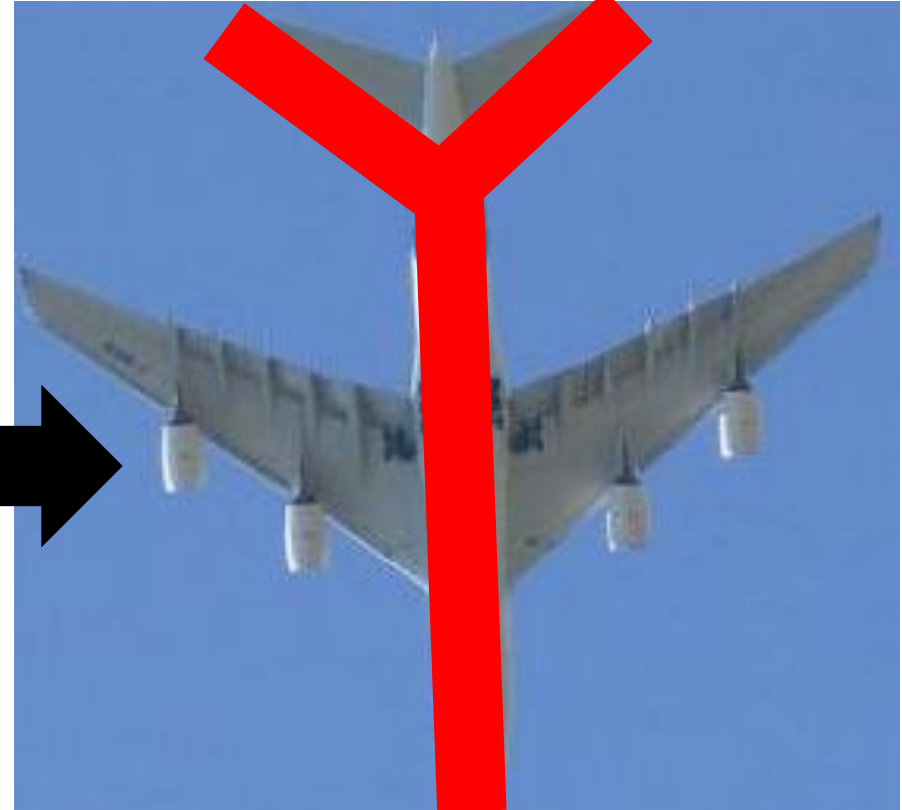

- DO-178B/C: Software Considerations in Airborne Systems and Equipment Certification (RTCA, EUROCAE)
- Steven P. Miller: Certification Issues in Model Based Development (Rockwell Collins)

Main ideas of MDE → DO-178C

- early validation of system models
- automatic source code generation
- reduce development costs

Models and Transformations in Avionics Systems Development

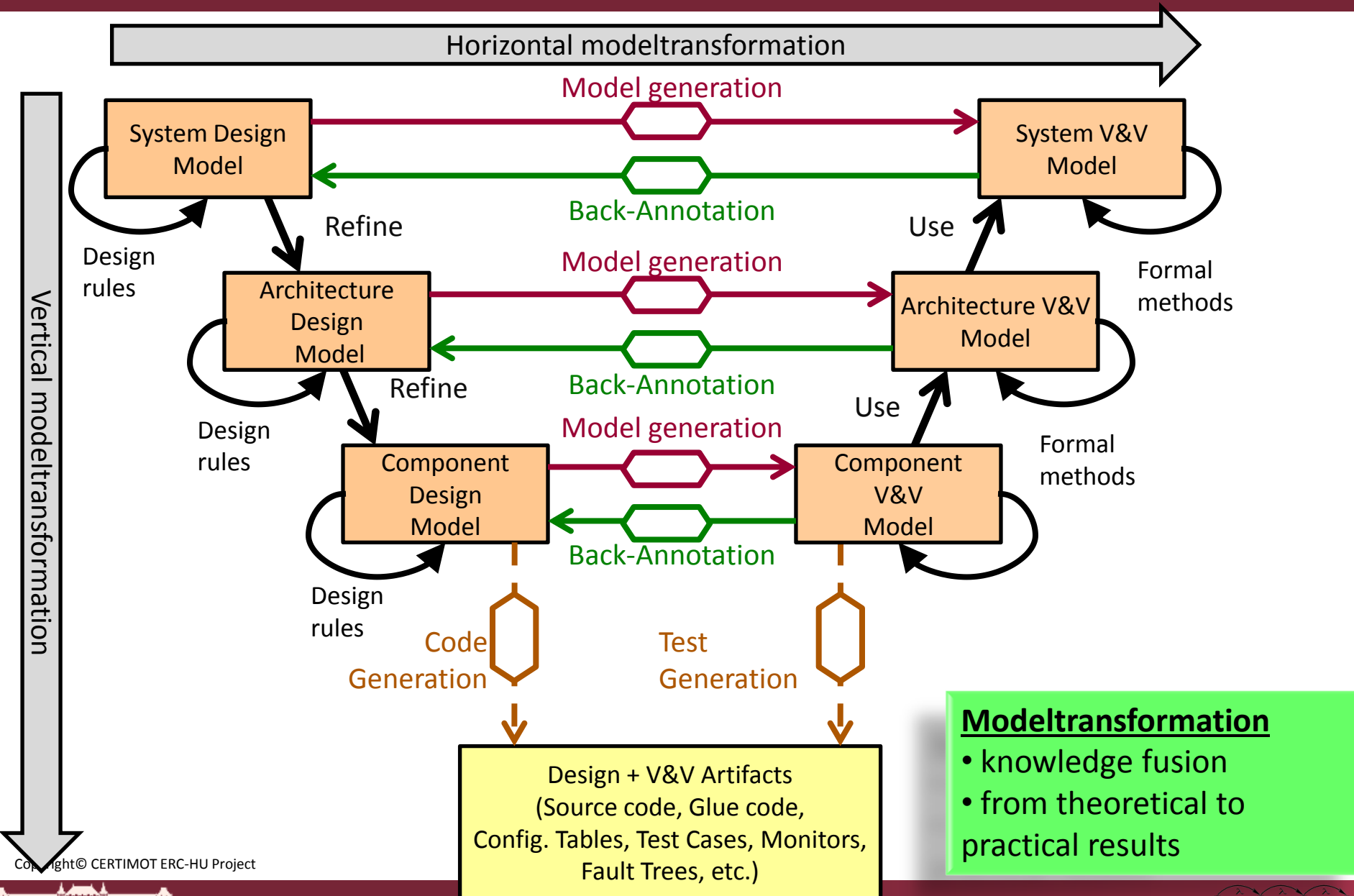

Definition of Modeltransformation

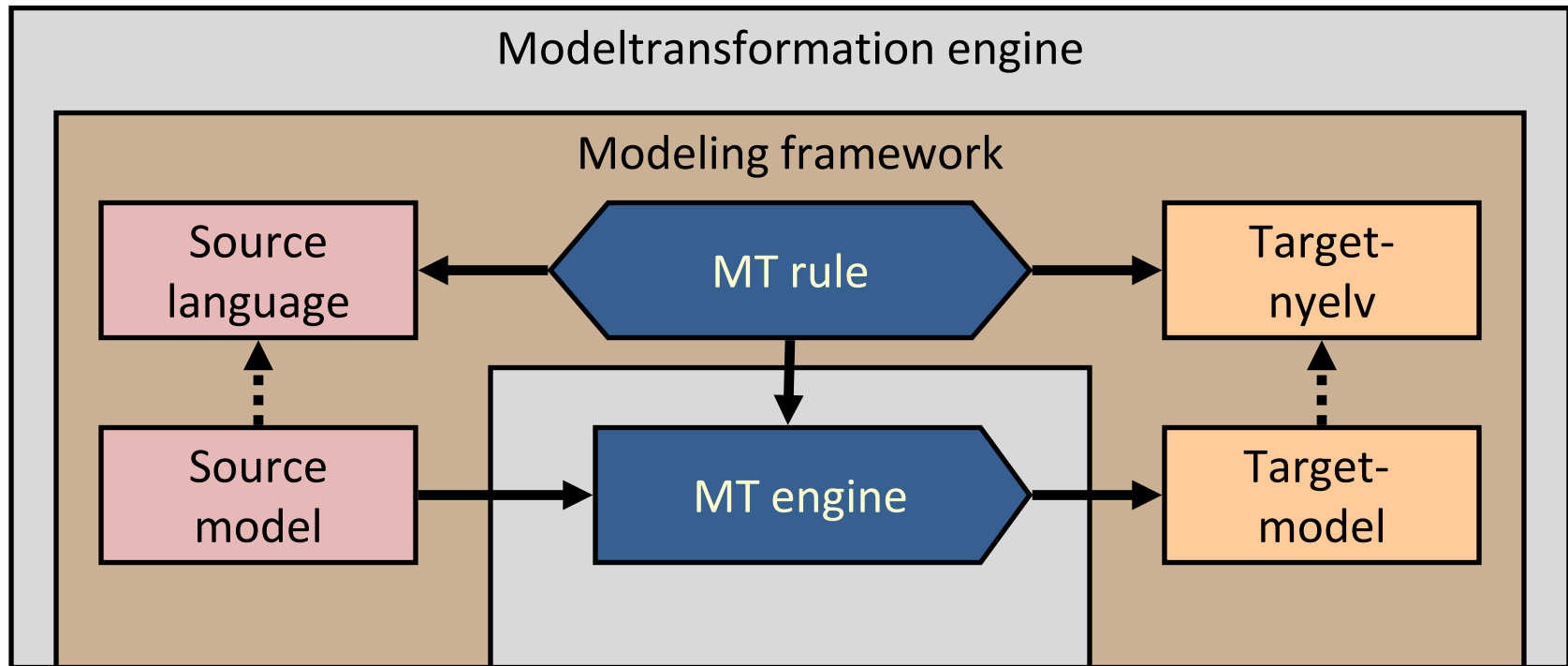

Áttekintés

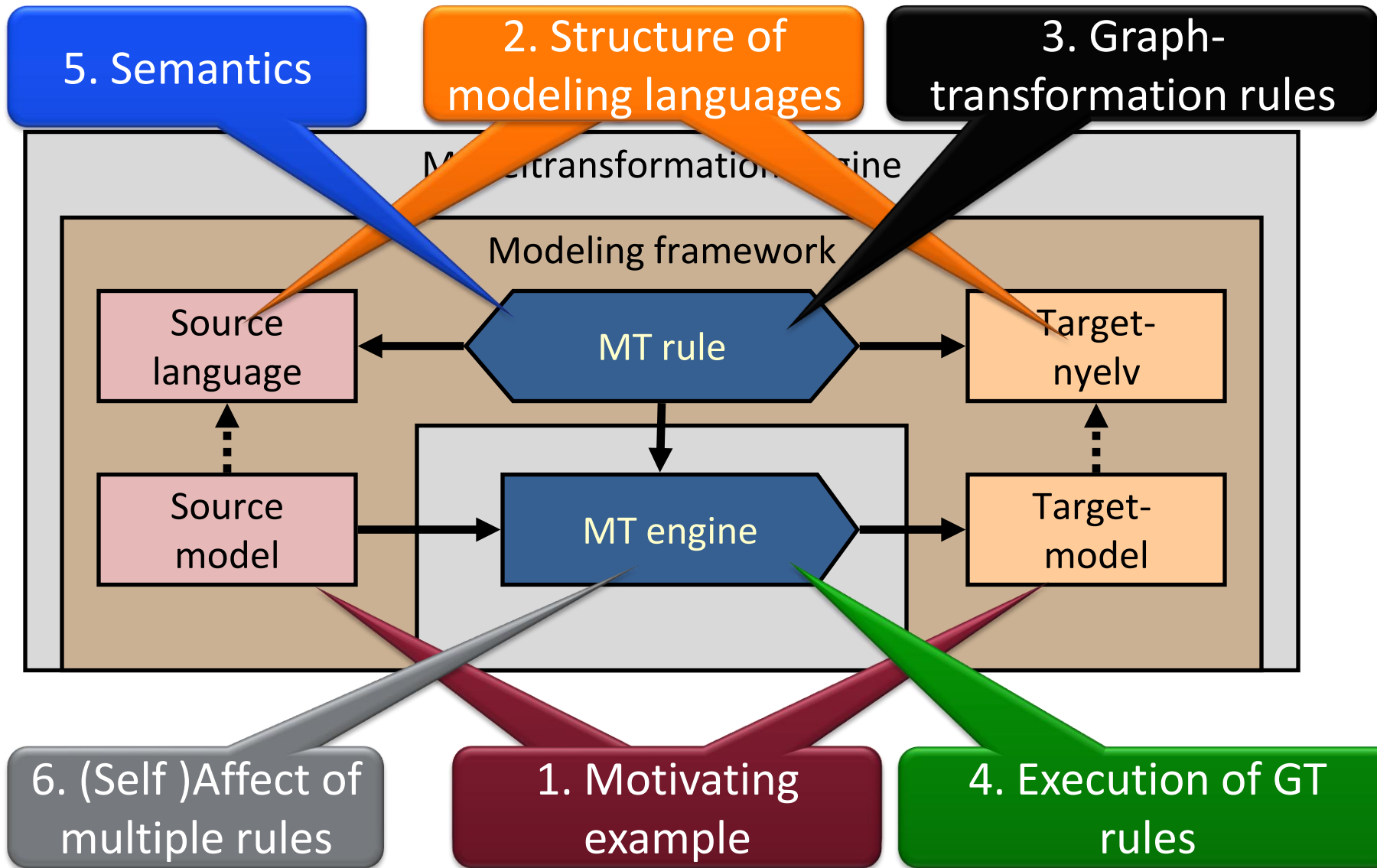

1. Motivating Example

Object Relation Schema mapping

Example: Object-relational mapping

- Important as:

- Modeltransformation benchmark
- Most widely used industrial modeltransformation (pl. Hibernate, EJB, CDO)

- Objective:

- **Input:**
UML class diagram
- **Output**
Relational database schema

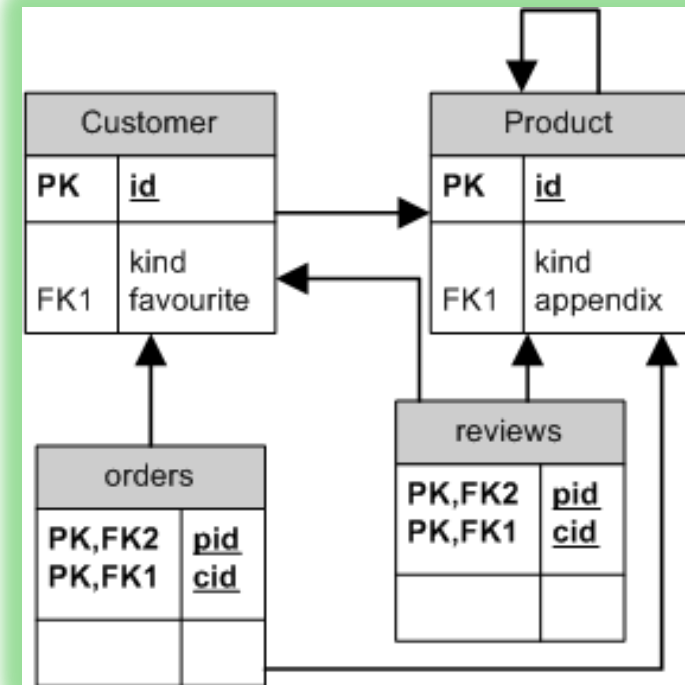
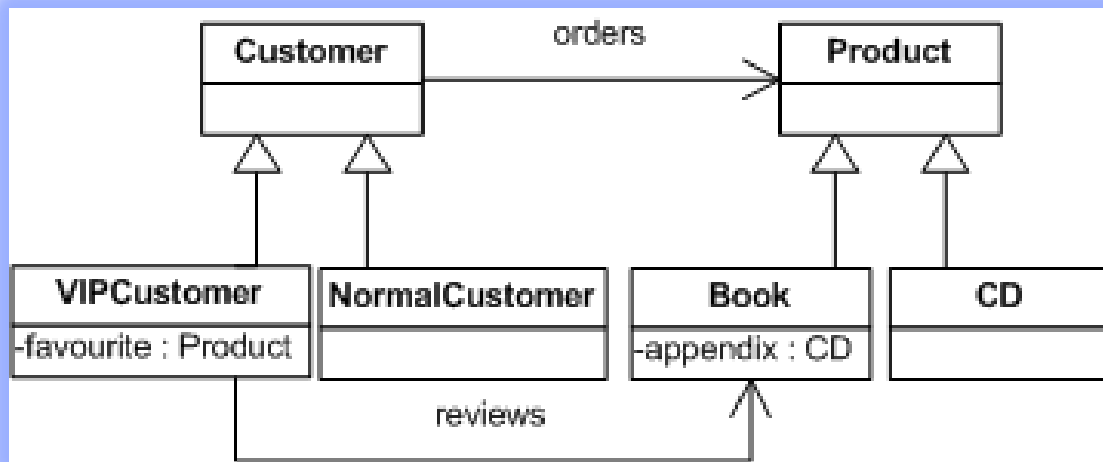

Informal definition of the MT rules of the mapping

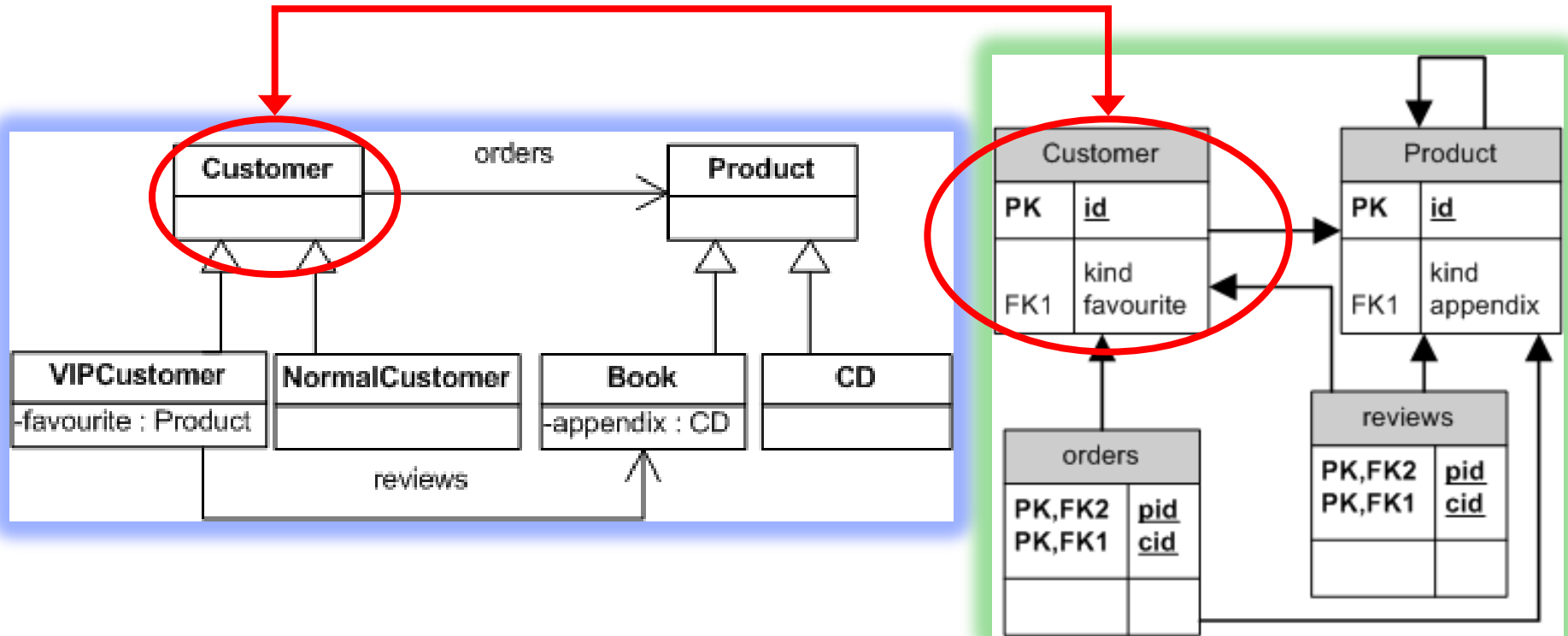

Topmost (generalization) classes → Database table + 2 column:

- Unique identifier (primary key),
- type definition

Informal definition of the MT rules of the mapping

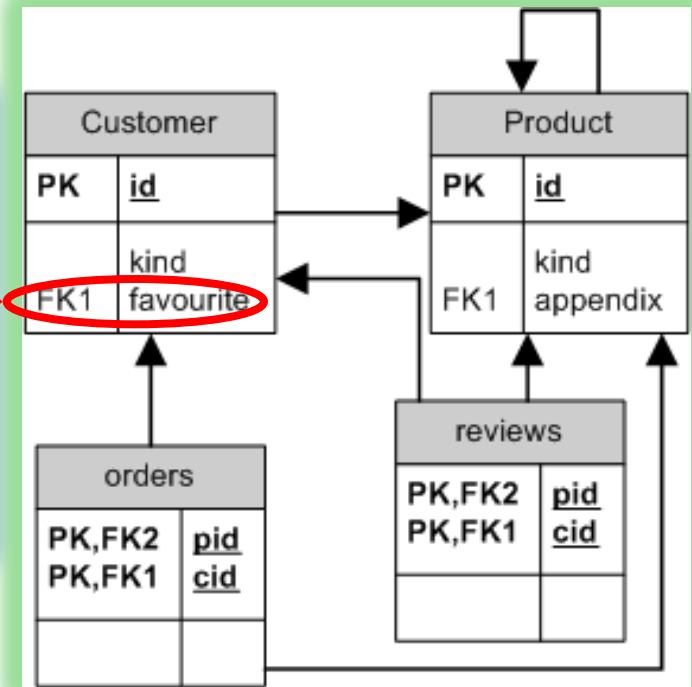
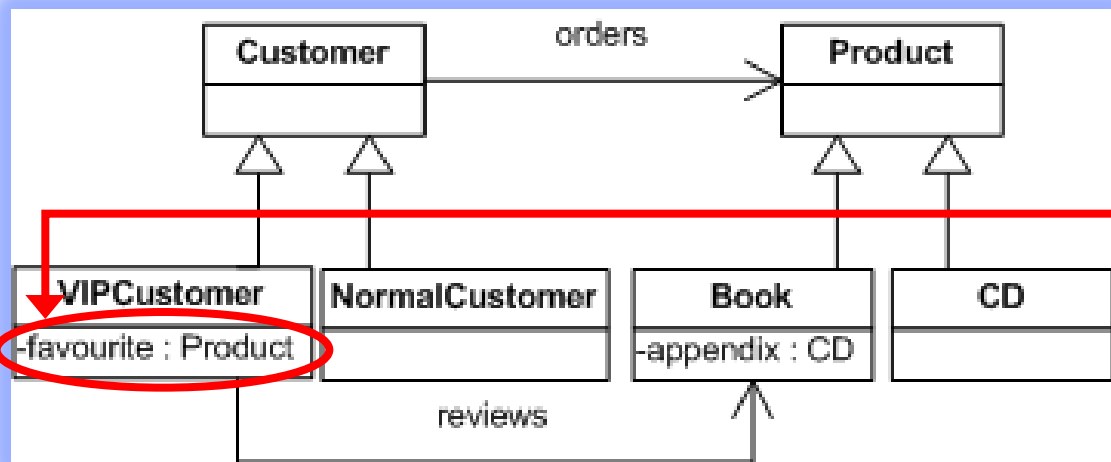

Class attributes → (contained by the topmost classes) Column of the table

Informal definition of the MT rules of the mapping

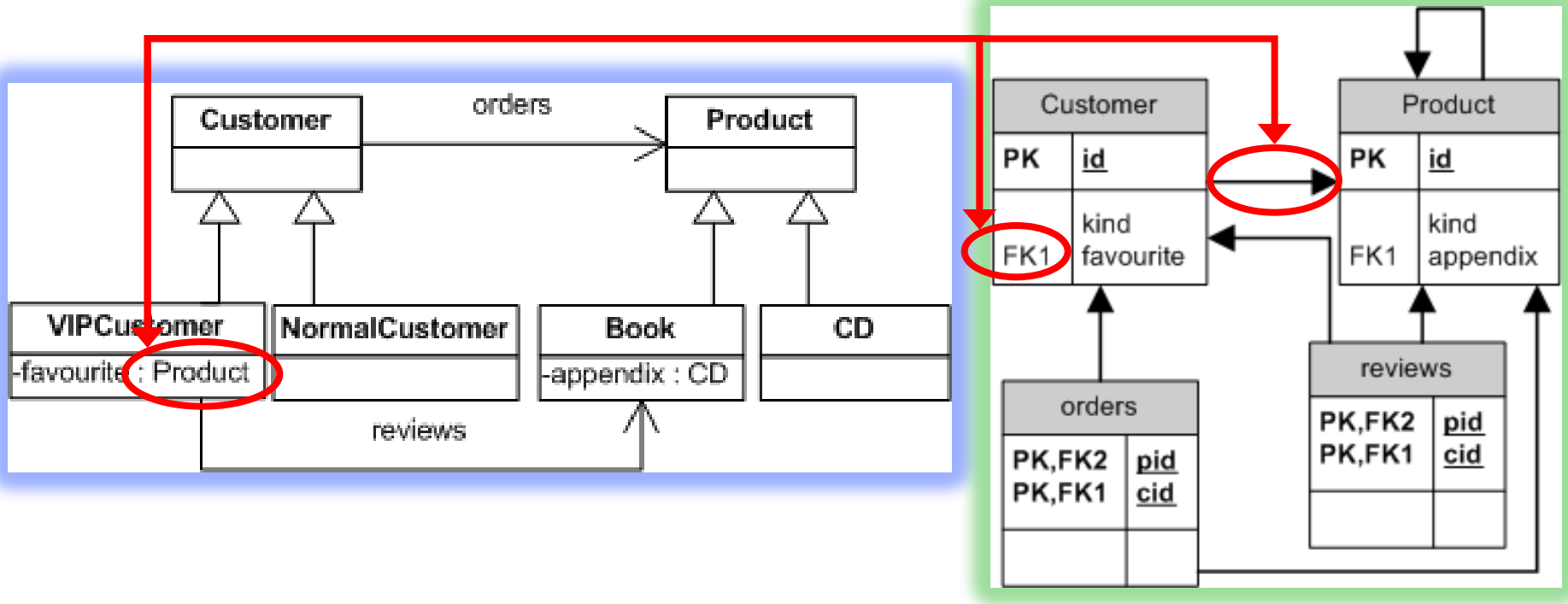

Type of the attributes → foreign key

Informal definition of the MT rules of the mapping

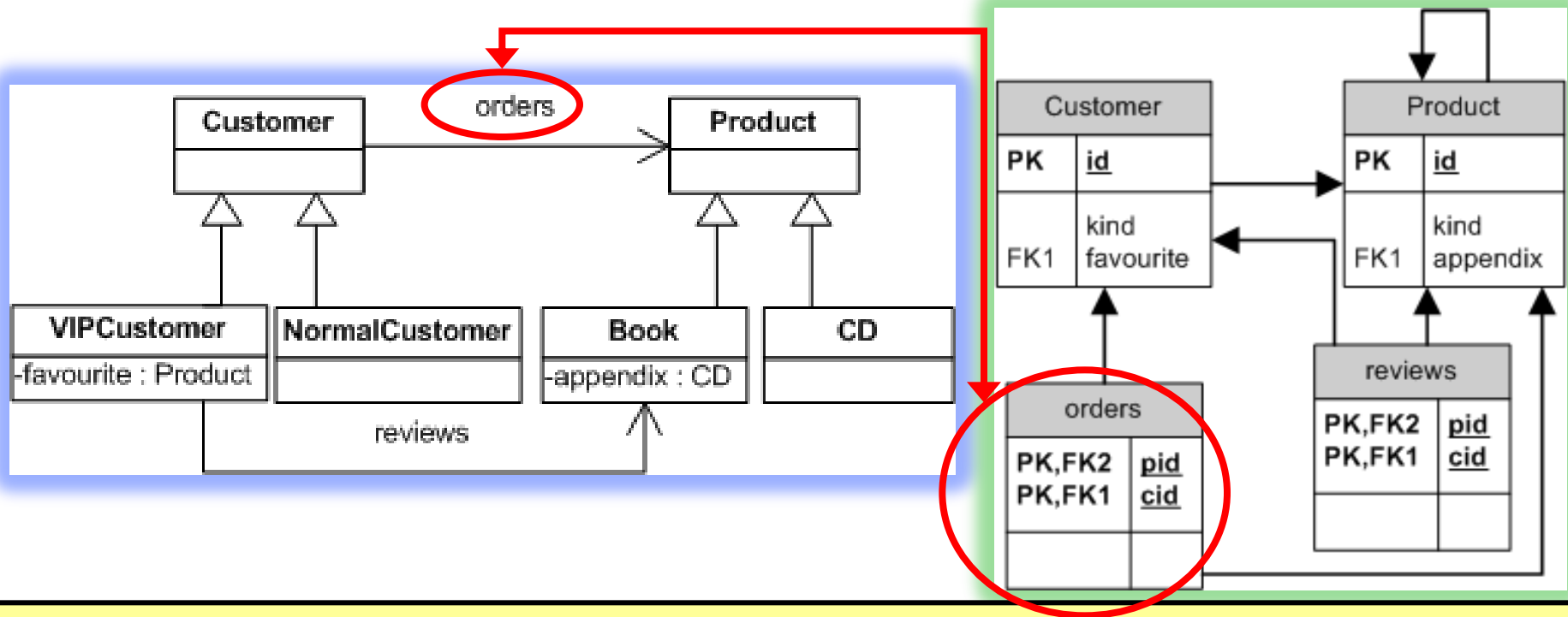

Association → A table with two columns

- source and target identifiers
- foreign keys (for consistency)

2. Structure of Modeling Languages

Overview

Structure of Modeling languages (UML)

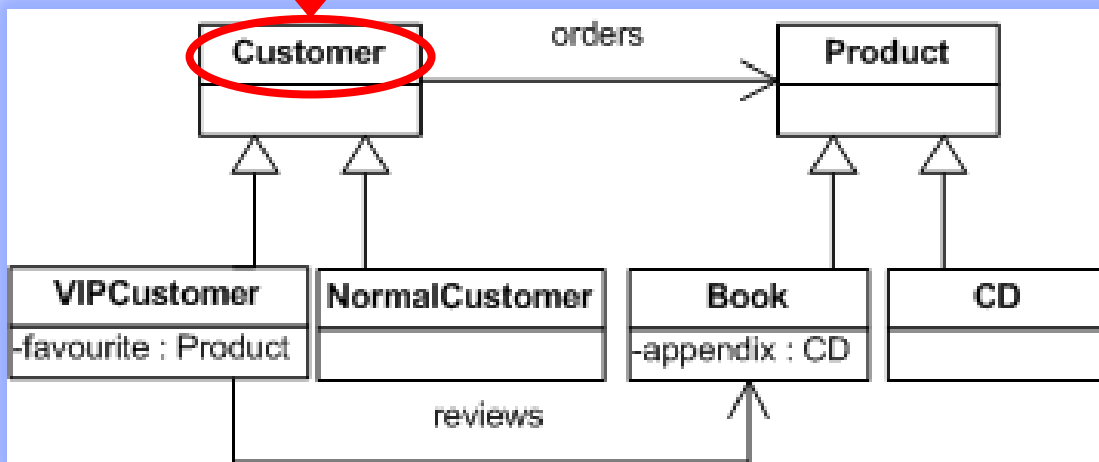
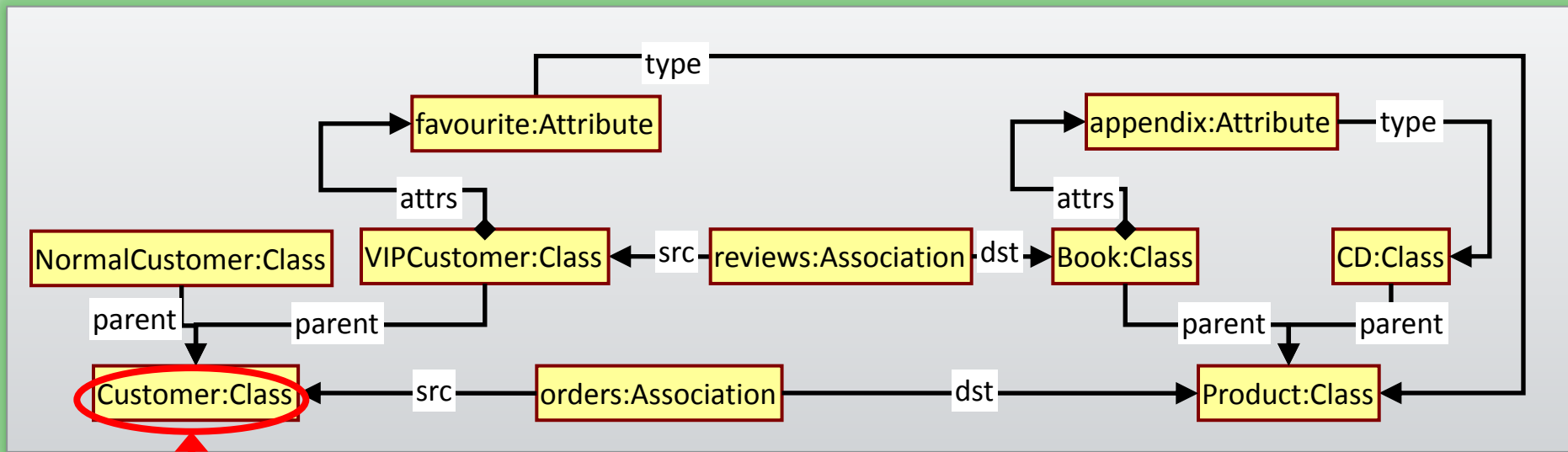

Abstract syntax

- Graph based model representation
- Machine readable

Concrete syntax

- Visual/textual representation
- Human readable

Structure of Modeling languages (RDBMS Schema)

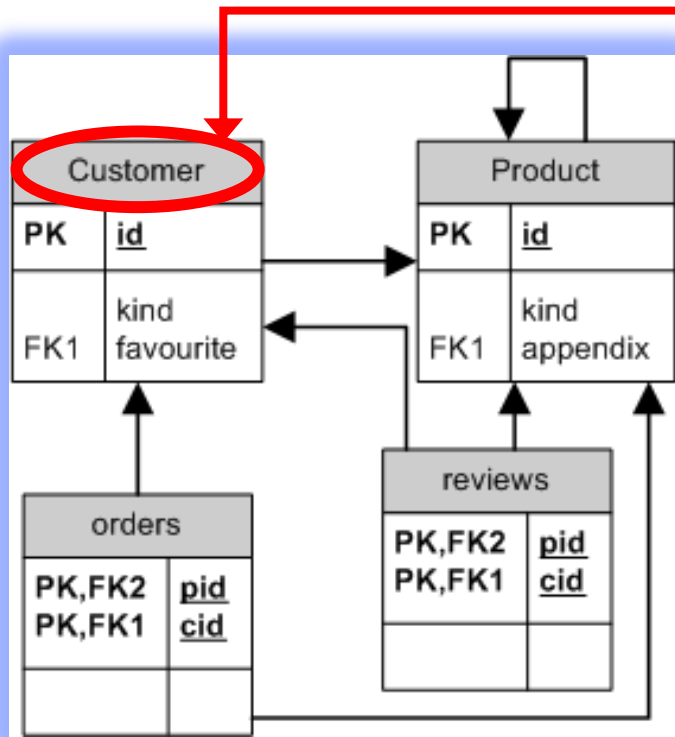

Concrete syntax

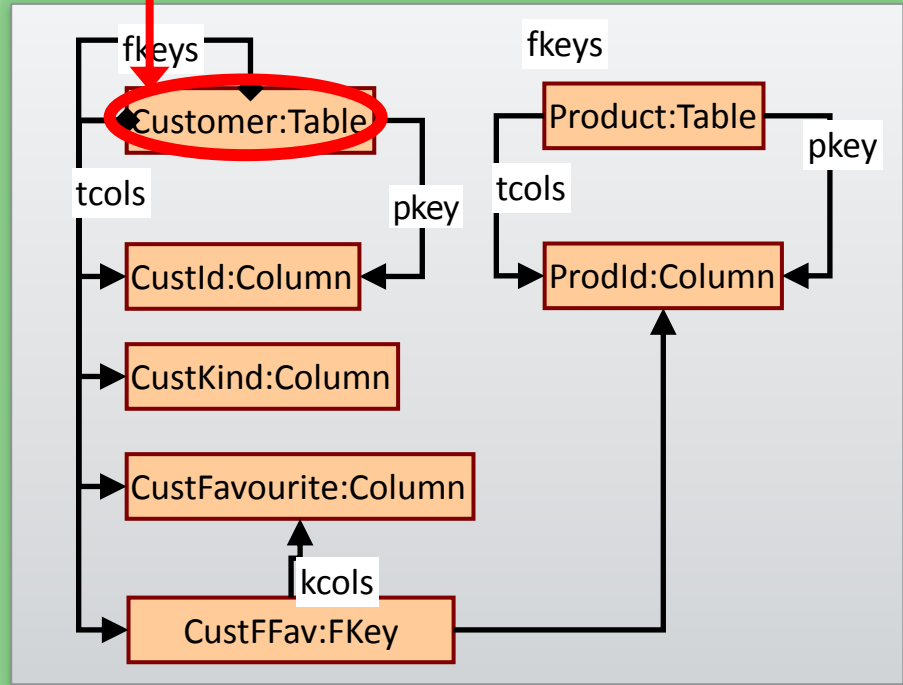

Abstract syntax

Metamodel: Definition of the Abstract Syntax

Metamodel

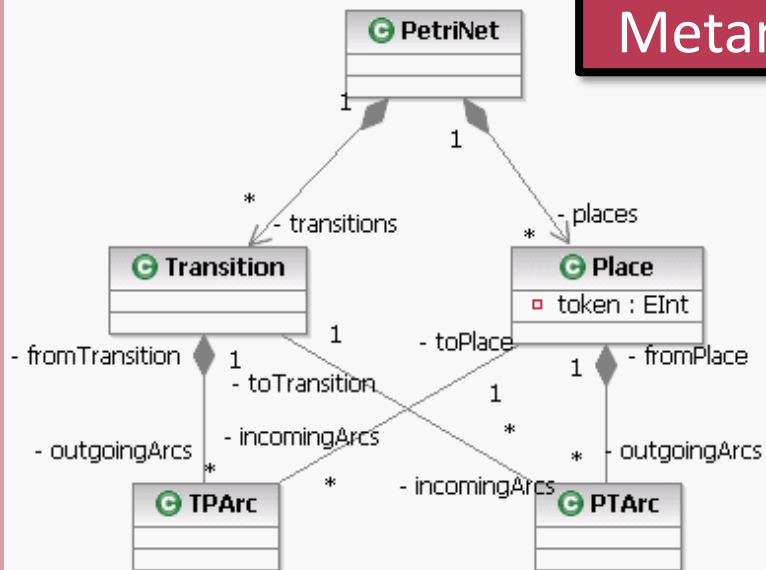

Metamodel:

- A language for defining the abstract syntax of other languages

Its goal: defining...

- The entities of the language
- The possible relation between them
- The attributes of the entities
- Abstraction/refinement (Taxonomy, Ontology) between the entities
- Containment and multiplicity constraints

Model

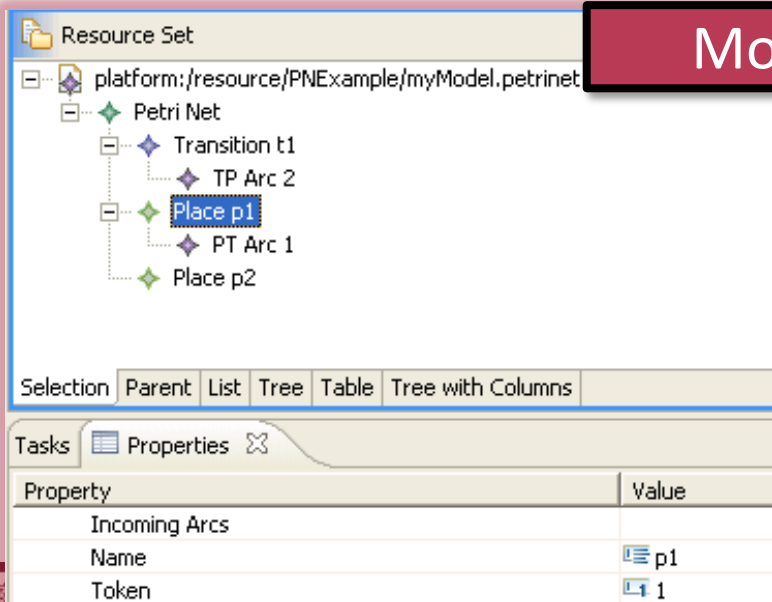

Metamodel of the O-R mapping

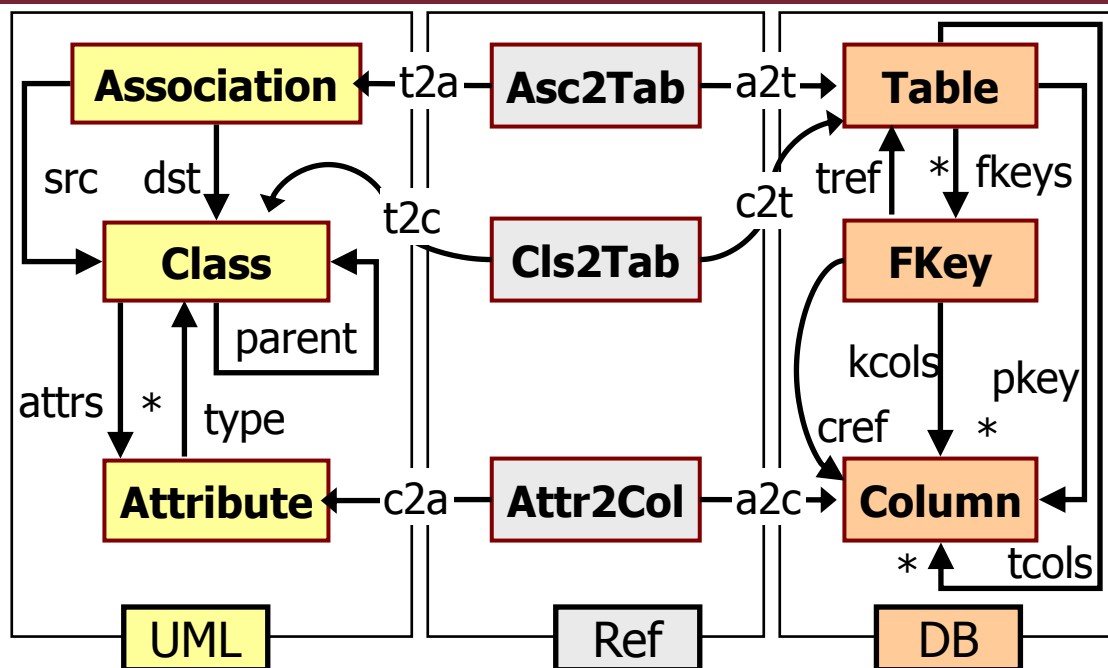

- Source + Target metamodel
- Traceability metamodel:
 - For saving the relations between the source and the target languages
- Motivation: critical embedded systems
 - Traceability
 - Requirement → Source code

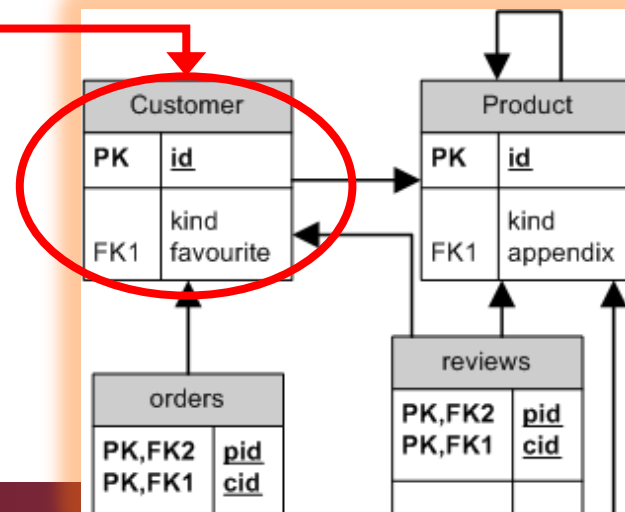
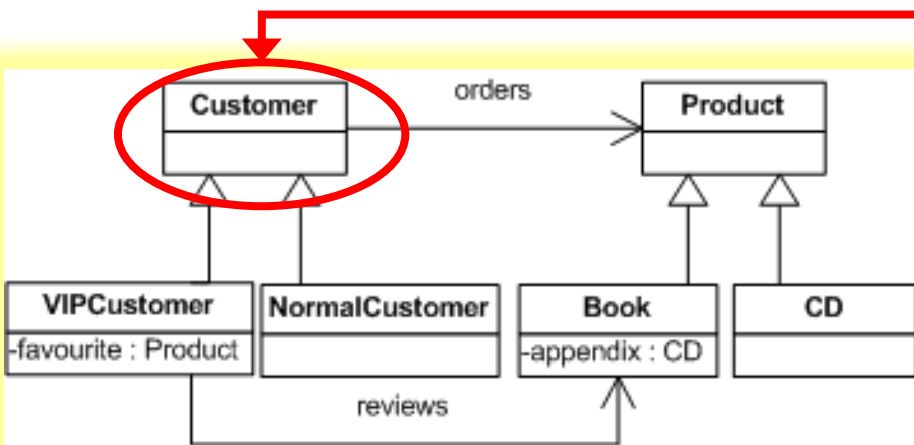

3. Graphtransformation rules

Structure of a GT rule

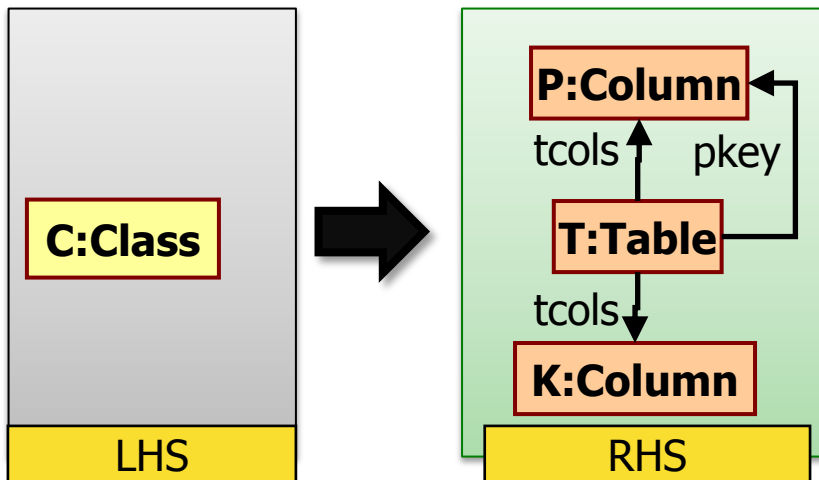

■ Graphtransformation rules

○ Left hand side - LHS

- Graph pattern
- Precondition for the rule application

○ Right hand side - RHS:

- Graph pattern + LHS mapping
- Declarative definition of the rule application
 - What we get (and not how we get it)

■ Graphtransformation (GT):

- Declarative and formal paradigm
- Rule base transformation
- Match of the LHS → match of the RHS
- Generalization of Chomsky grammars (hierarchy) (text → graph)

Structure of a GT rule

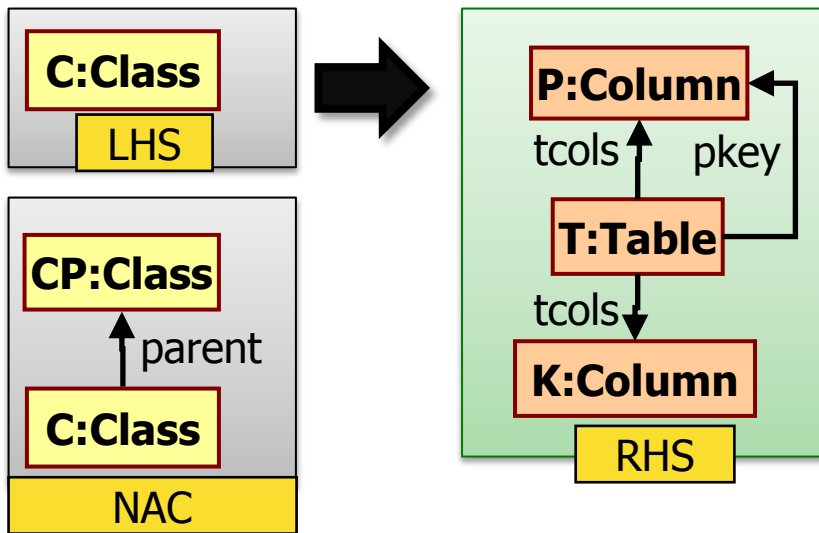

■ Graphtransformation rules

- **Left hand side - LHS**
 - Graph pattern
 - Precondition for the rule application

- **Right hand side - RHS:**

- Graph pattern + LHS mapping
- Declarative definition of the rule application

- What we get (and not how we get it)

- **Negative Application Condition(NAC):**

- Graph pattern + LHS mapping
- Negative precondition of the rule application
- If it can be made true → the rule cannot be applied
- Multiple NACs → only one is true → rule cannot be applied

■ Graphtransformation (GT):

- Declarative and formal paradigm
- Rule base transformation
- Match of the LHS → match of the RHS
- Generalization of Chomsky grammars (hierarchy) (text → graph)

Structure of a GT rule

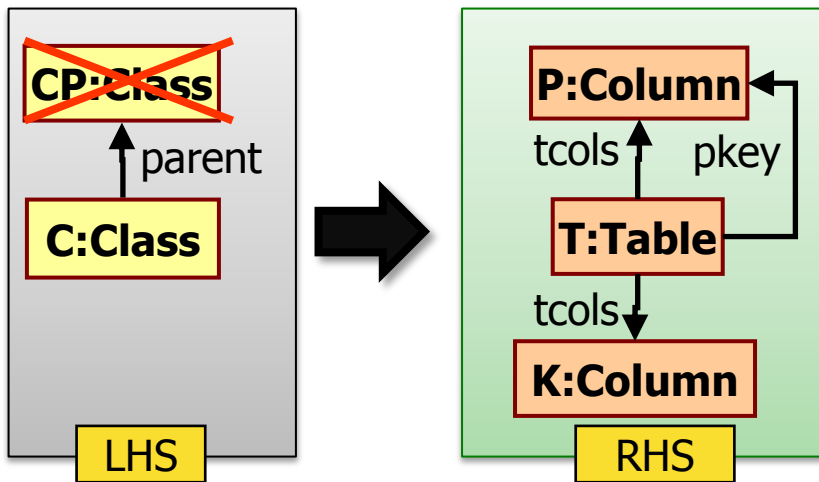

■ Graphtransformation (GT):

- Declarative and formal paradigm
- Rule base transformation
- Match of the LHS → match of the RHS
- Generalization of Chomsky grammars (hierarchy) (text → graph)

■ Graphtransformation rules

- **Left hand side - LHS**
 - Graph pattern
 - Precondition for the rule application
- **Right hand side - RHS:**
 - Graph pattern + LHS mapping
 - Declarative definition of the rule application
 - What we get (and not how we get it)
- **Negative Application Condition(NAC):**
 - Graph pattern + LHS mapping
 - Negative precondition of the rule application
 - If it can be made true → the rule cannot be applied
 - Multiple NACs → only one is true → rule cannot be applied

4. Application of Graphtransformation rules

Application of GT rules

1. Graph pattern matching

- Match of the LHS pattern in the underlying model
- match m : LHS \rightarrow G mapping

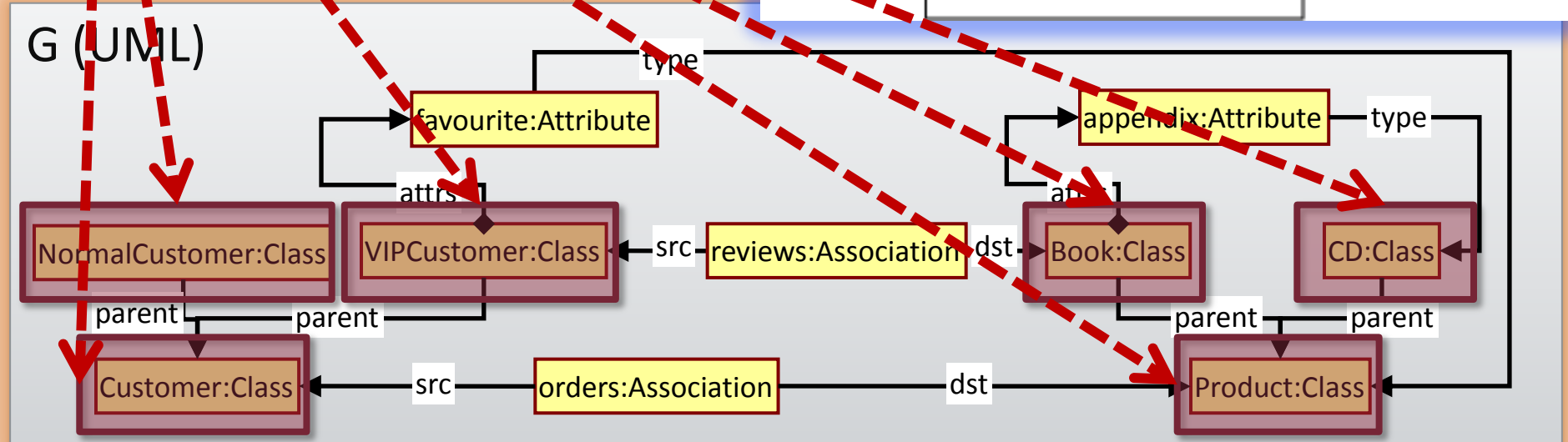
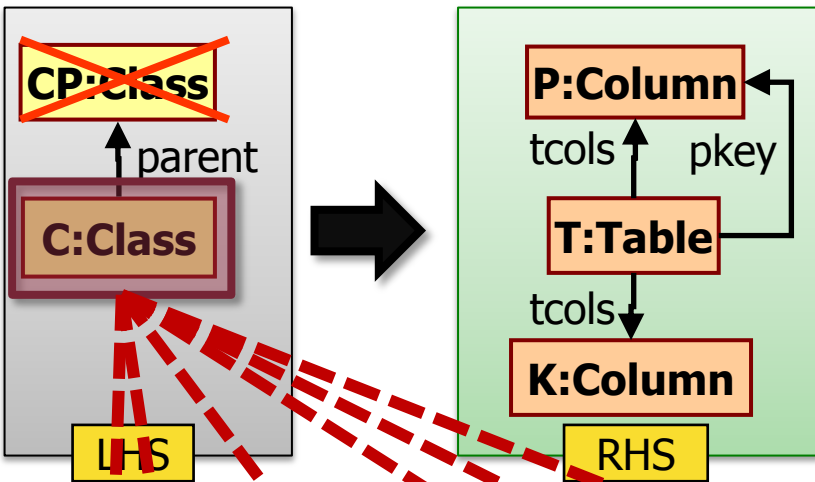
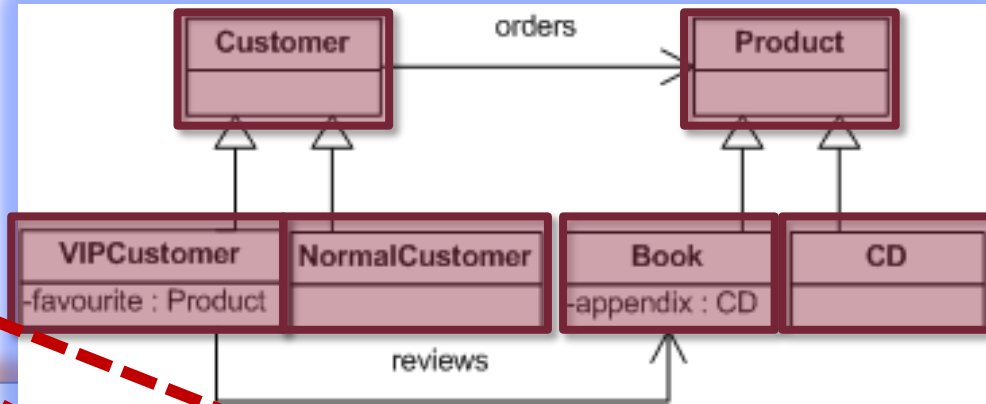

Application of GT rules

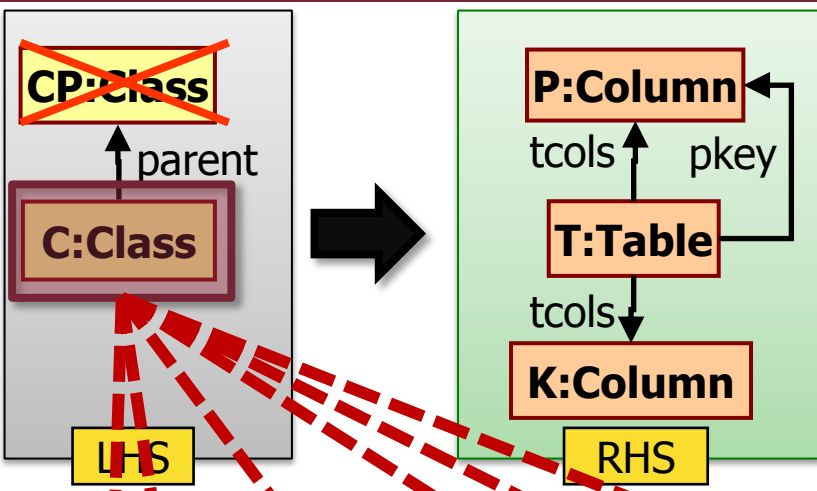

NAC check

Is there a match g for the NAC in G along the $m: LHS \rightarrow G$ match?

Successful match of NAC $\rightarrow m$ is not a match

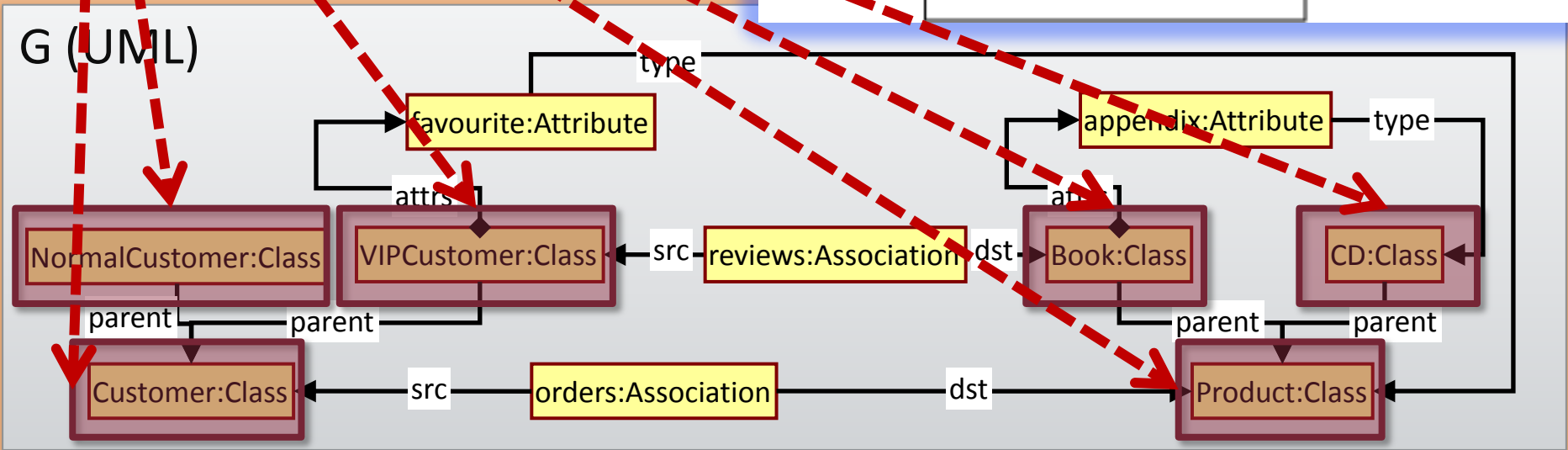
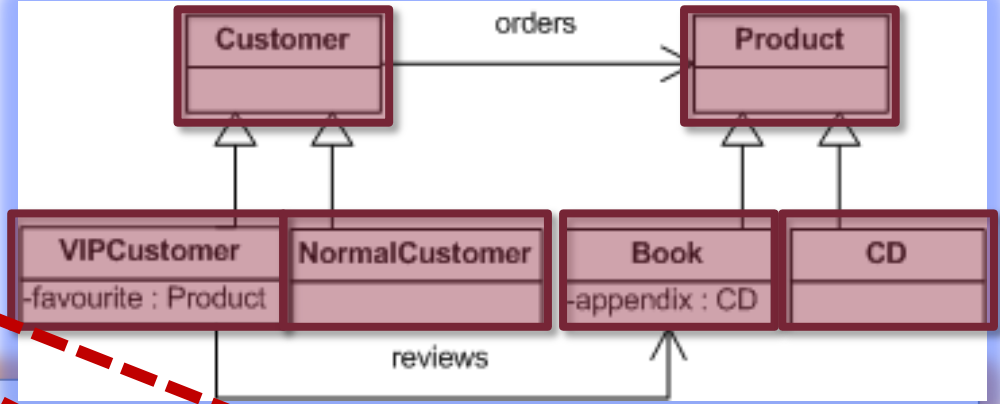

Application of GT rules

3. Nodeterministic selection

- Random selection of a match (if more than one)
- No match → rule fails

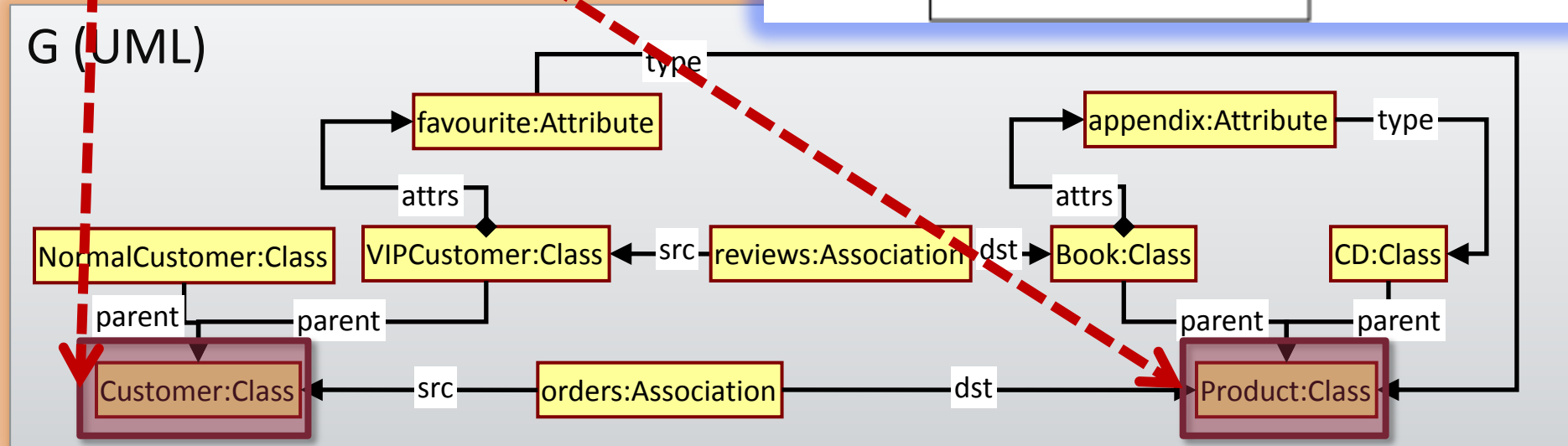
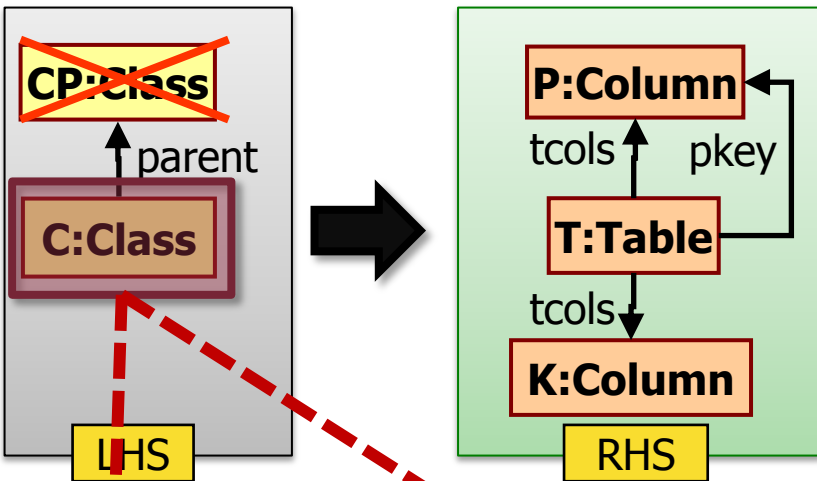
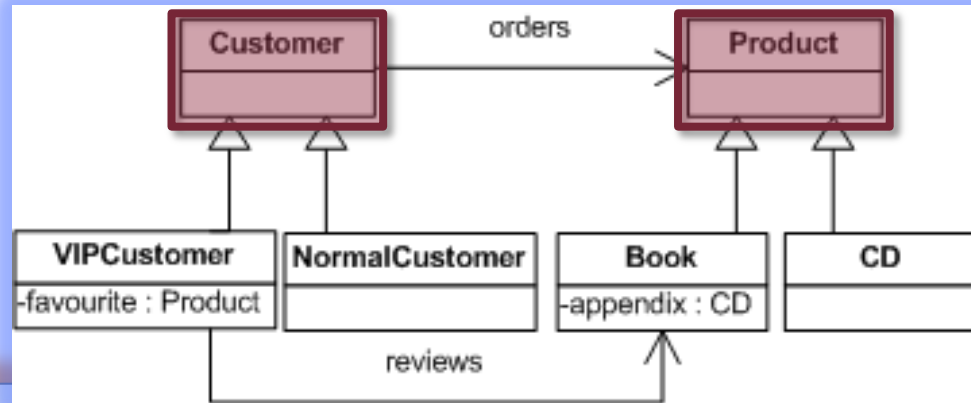

Application of GT rules

4. Deletion

- Deletion of LHS \ RHS from G
- In LHS yes, in RHS no

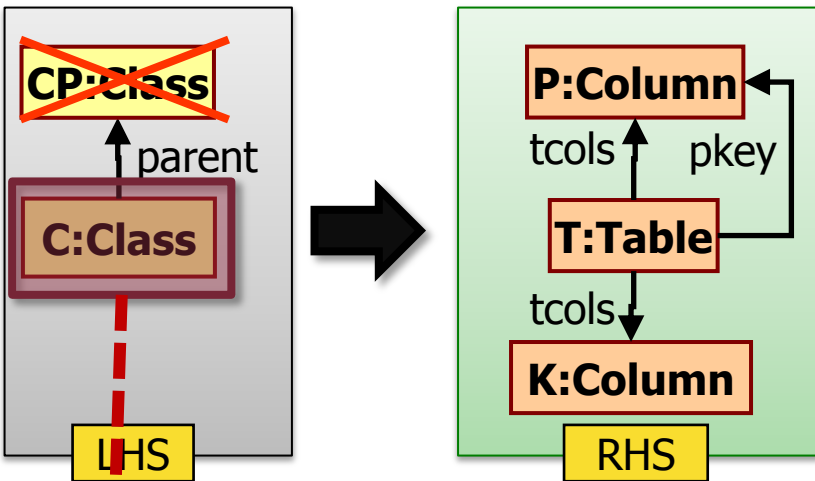
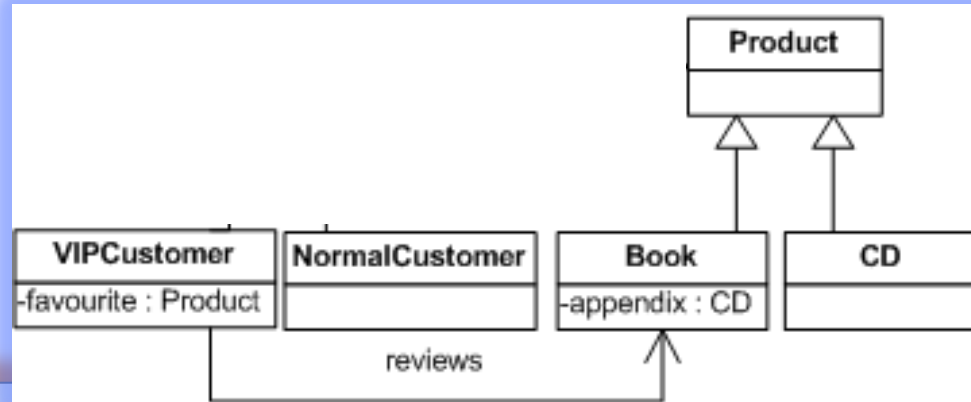

G (UML)

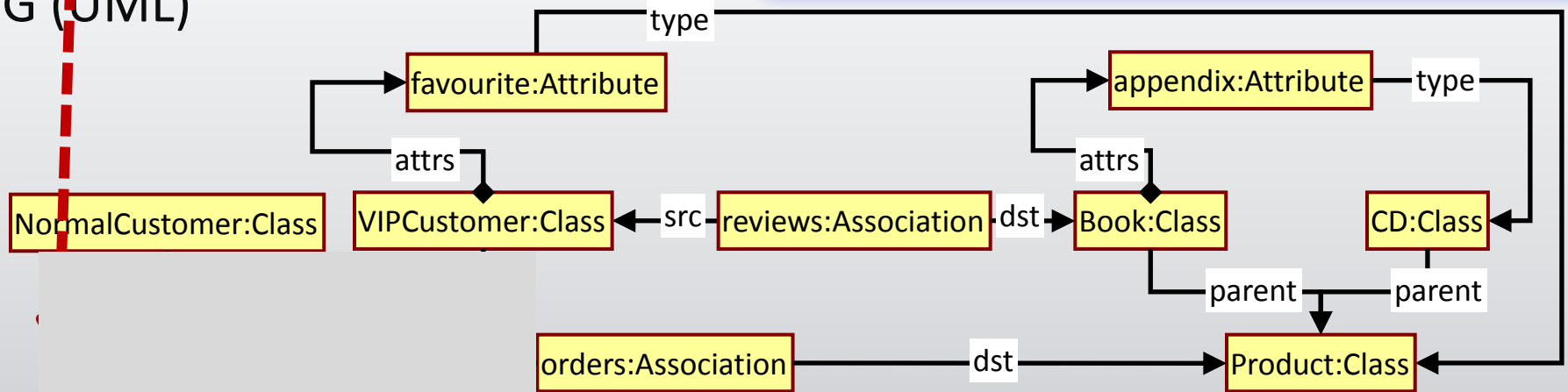

Application of GT rules

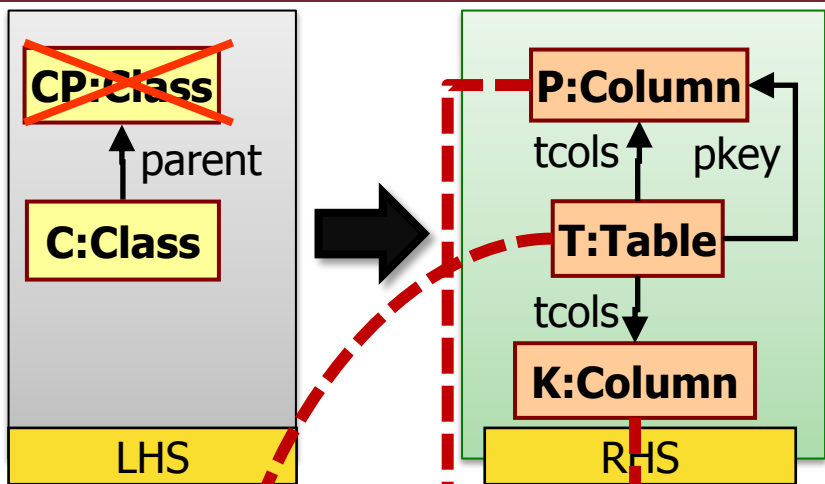

5. Creation (and binding)

- Creation of RHS \ LHS in G with their corresponding relations
- Output: a „match” of LHS in G

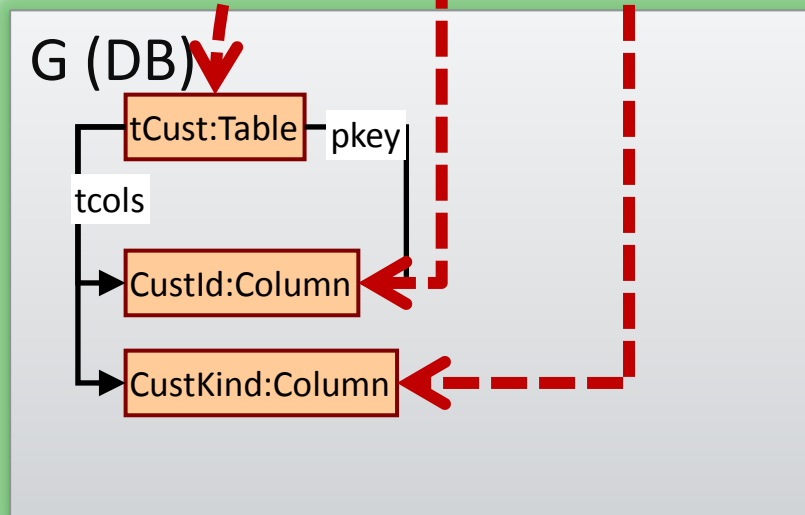

Customer	
PK	<u>id</u>
	kind

Typical problems...

1) Saving the source model, traceability

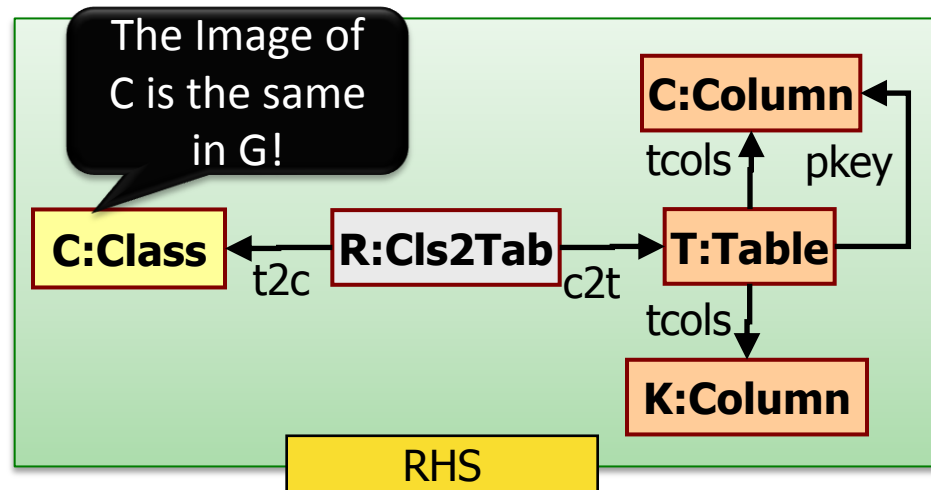
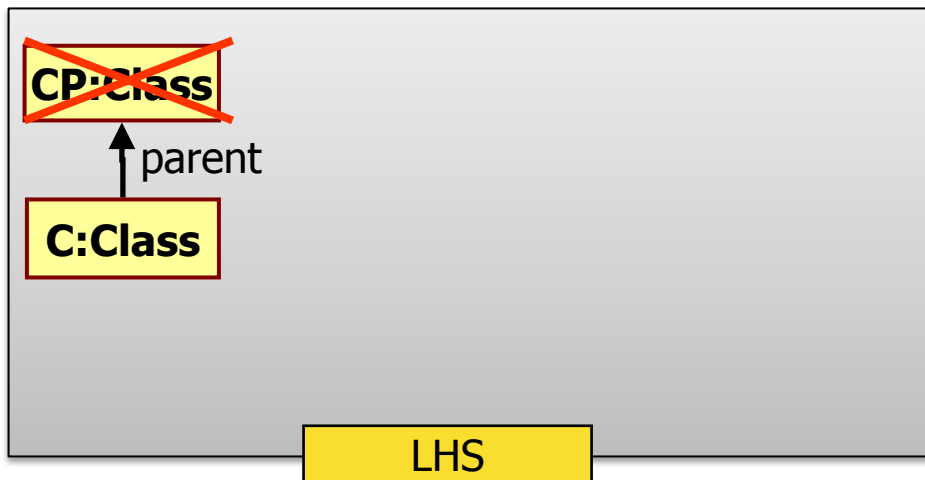

2) Application of the same rule along the same match

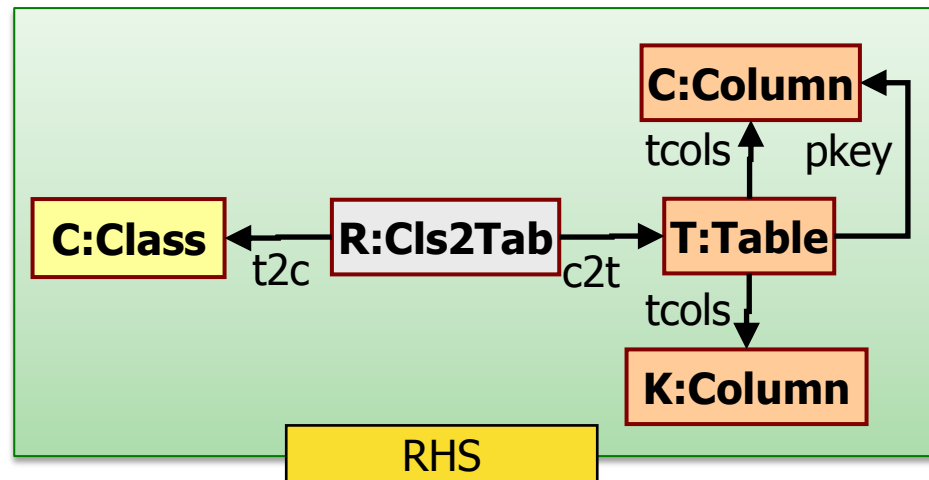
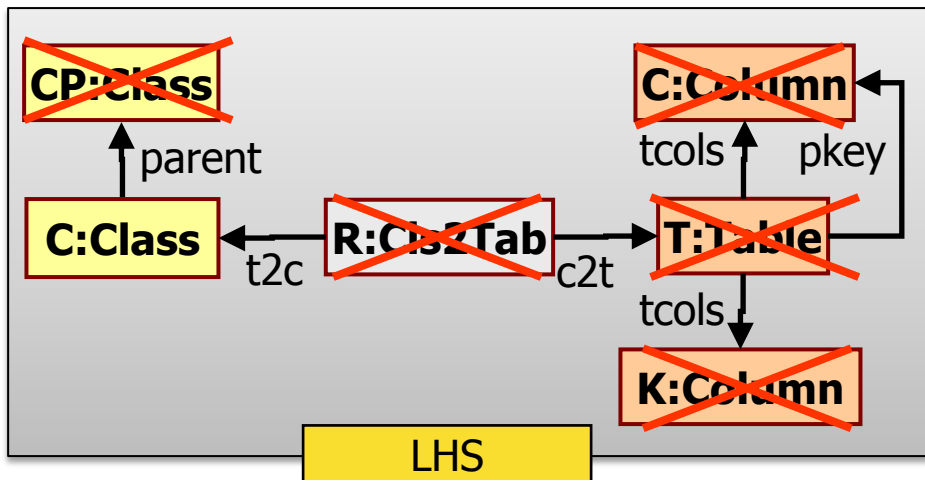

5. Different Semantics

Semantics : Handling of Dangling edges

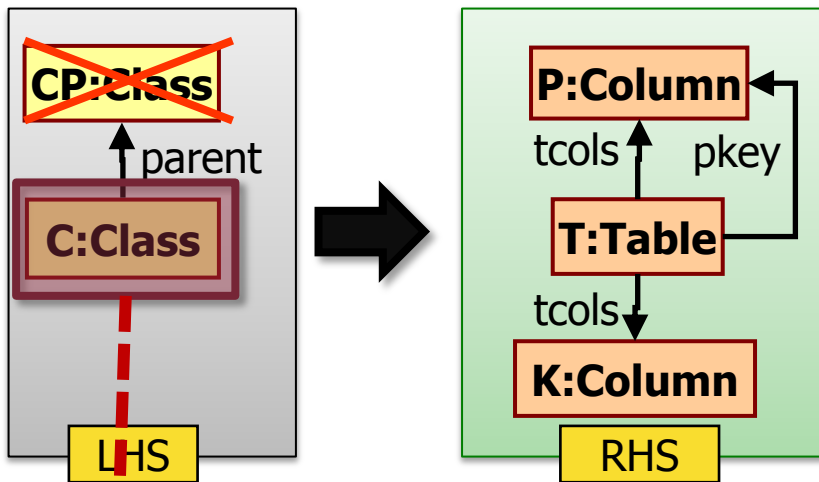

■ Dangling edges:

- Delete a node
 - What to do with the dangling edges?

■ Greedy approach

- Delete all dangling edges
- **Pro:**
 - Intuitive for engineers
 - Easy to implement
- **Con:**
 - Verification is hard (side effect of rules)

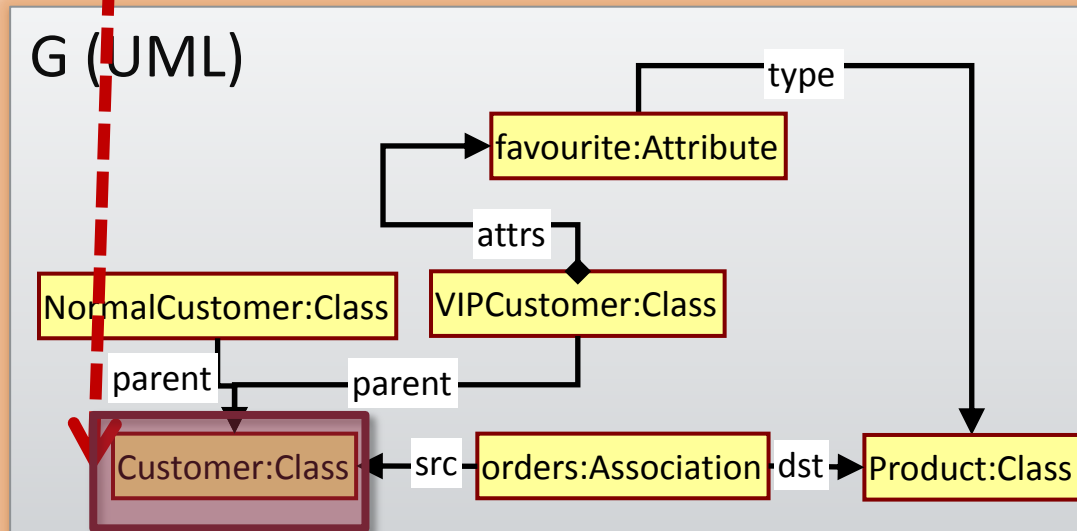

Semantics : Handling of Dangling edges

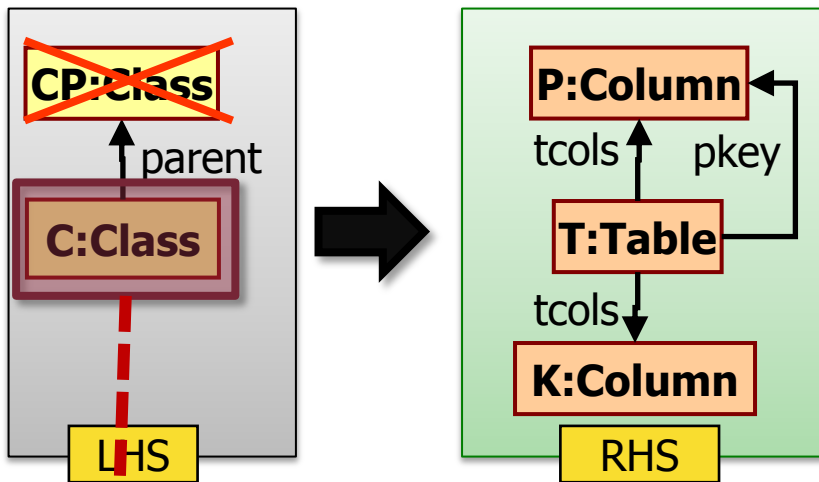

■ Dangling edges:

- Delete a node
 - What to do with the dangling edges?

■ Conservative approach

- The rule cannot be applied if it would produce a dangling edge
- **Pro:**
 - Side effect free rules
 - Helps verification
- **Con:**
 - Harder to implement
 - What is its meaning for engineers (not mathematicans)

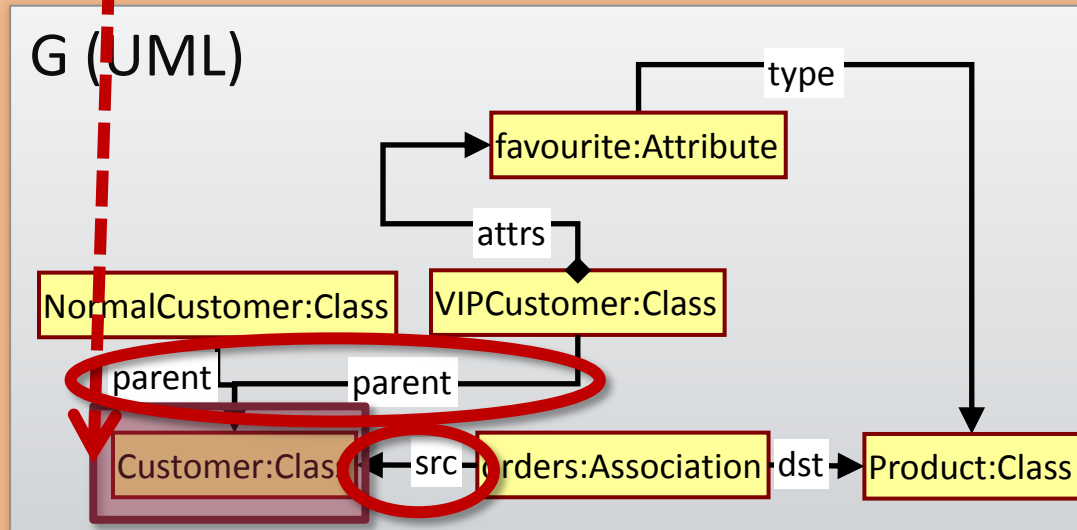

Semantics: Injective matching

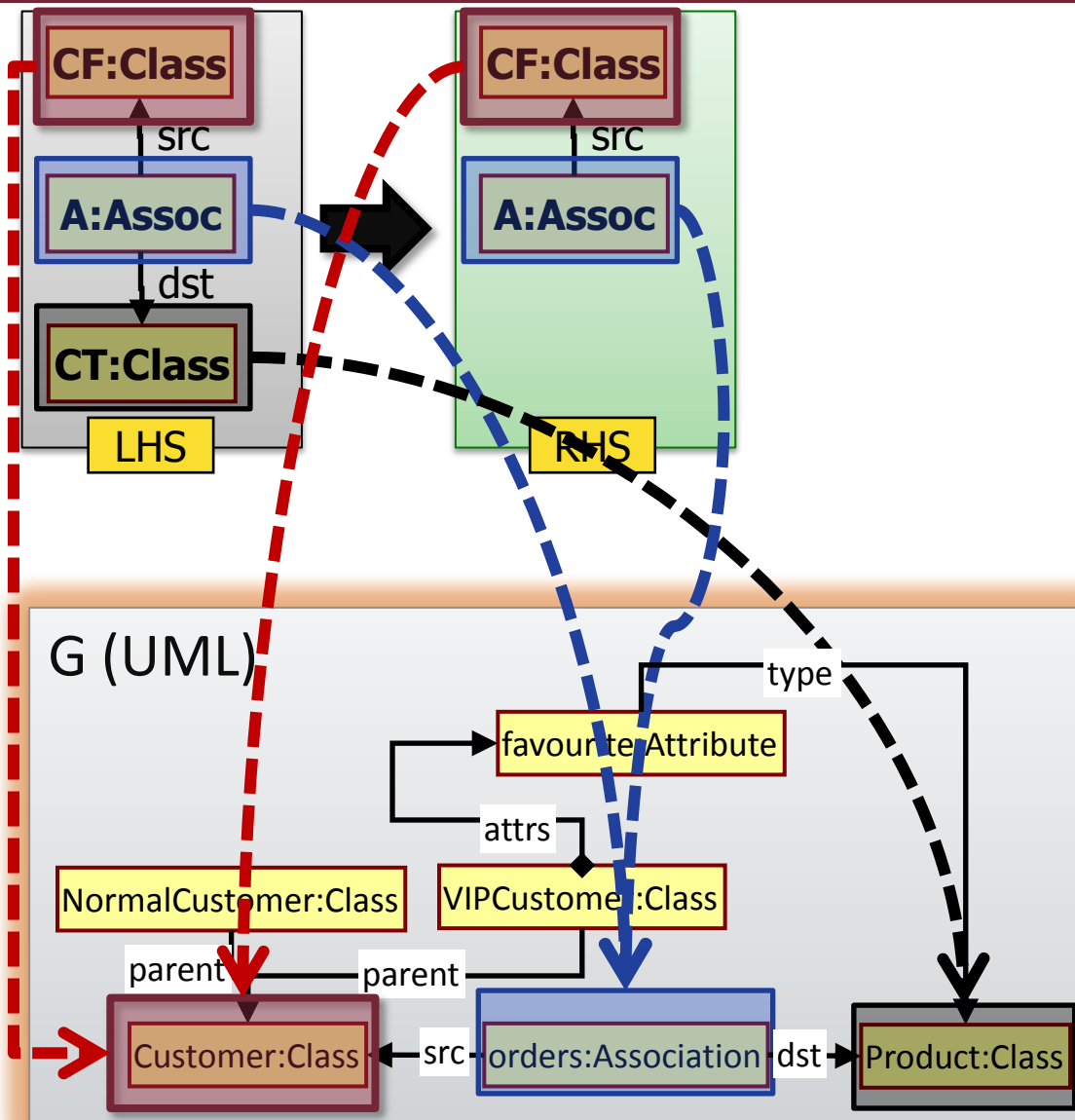

Injective matching („kisajátító”)

- For all nodes in the LHS → separate nodes are matched in G
- **Pro:**
 - Intuitive for engineers
- **Con:**
 - Verbose specification of rules (many alternate subrules)

Semantics: Non-injective matching

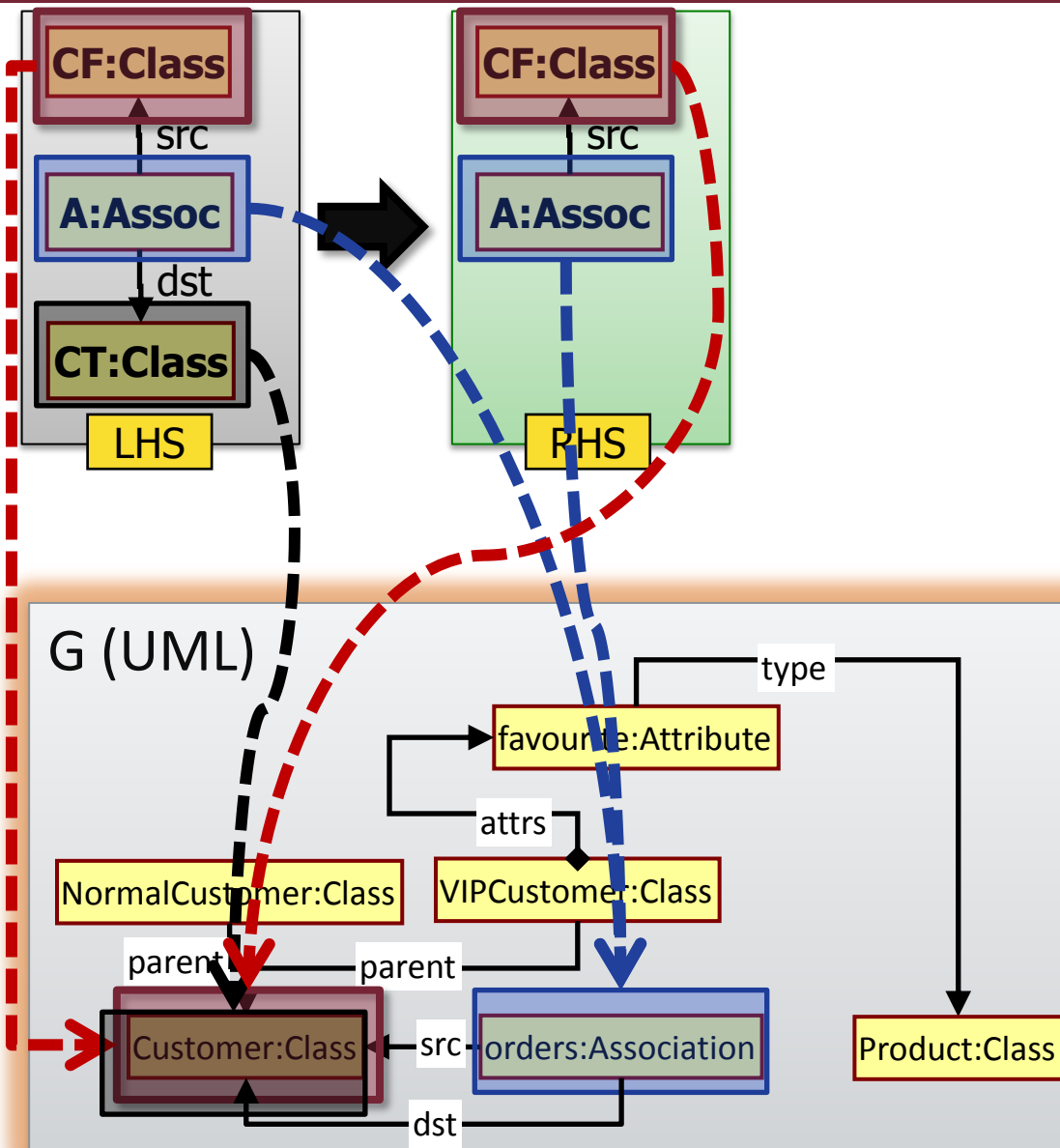

- **Non-Injective matching („közösködő“)**

- For multiple nodes in the LHS → the same node can be matched in G

- **Con:**

- Contradictory specification for a node
 - For **CF** : keep it
 - For **CT** : delete

- **Solution:**

- Nodes to be deleted in LHS are matched with injectiv semantics

6. Affect of multiple GT rules

Conflict / Parallel independence

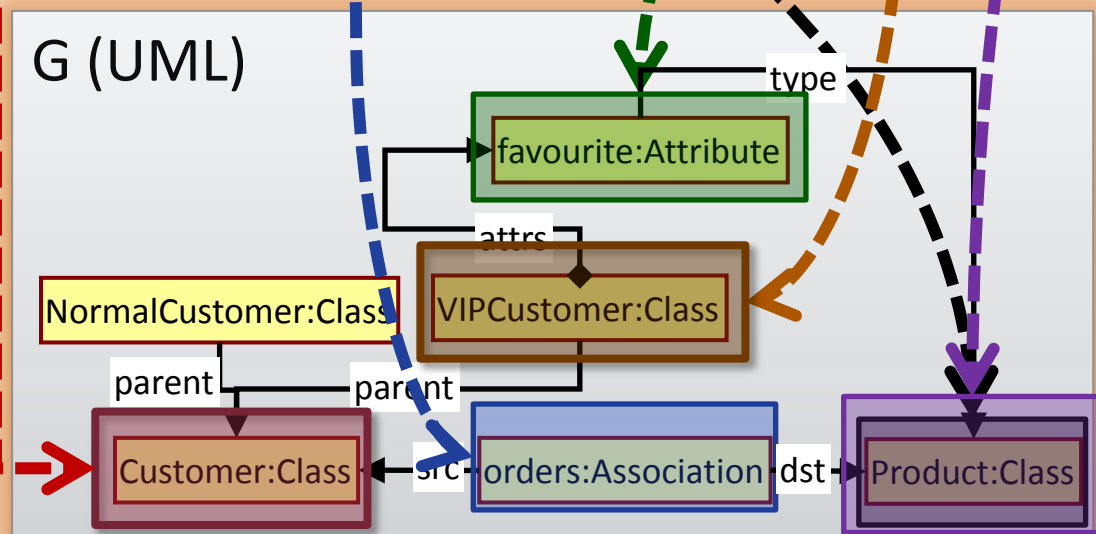
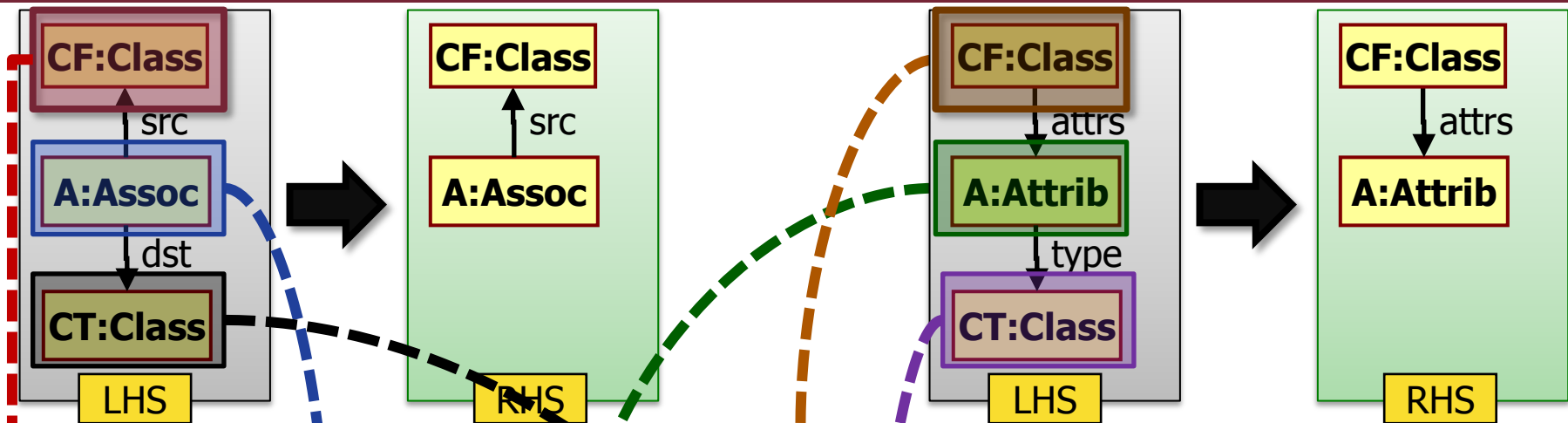

- **Parallel independence** (between two rule applications)
 - Neither affects the application of the other
- **Conflict** (between two rules)
 - If they are not parallel independent
- **Parallel independence** (between two rules)
 - Any two of their rule application are parallel independent

Serial independence

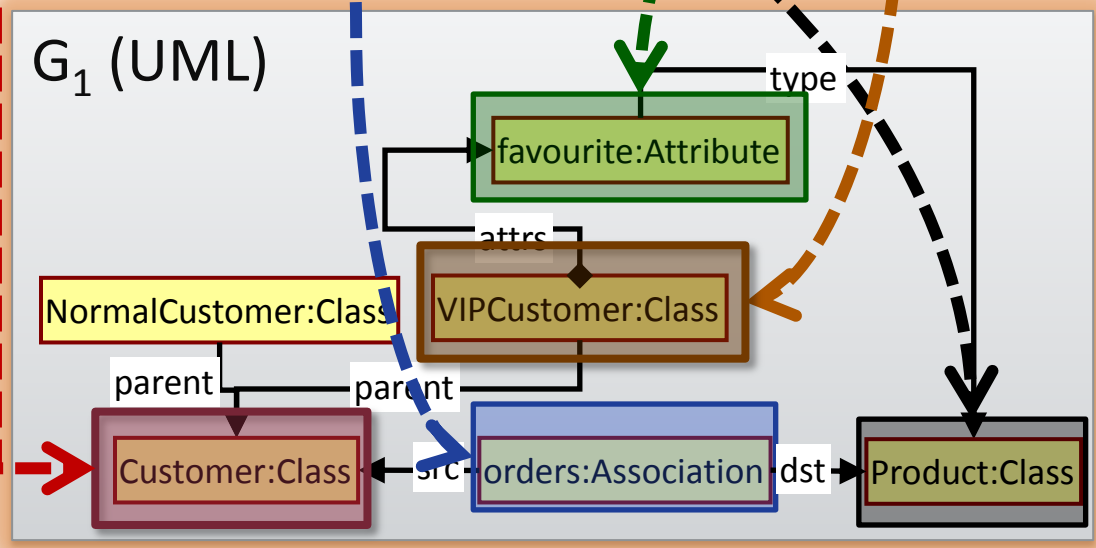
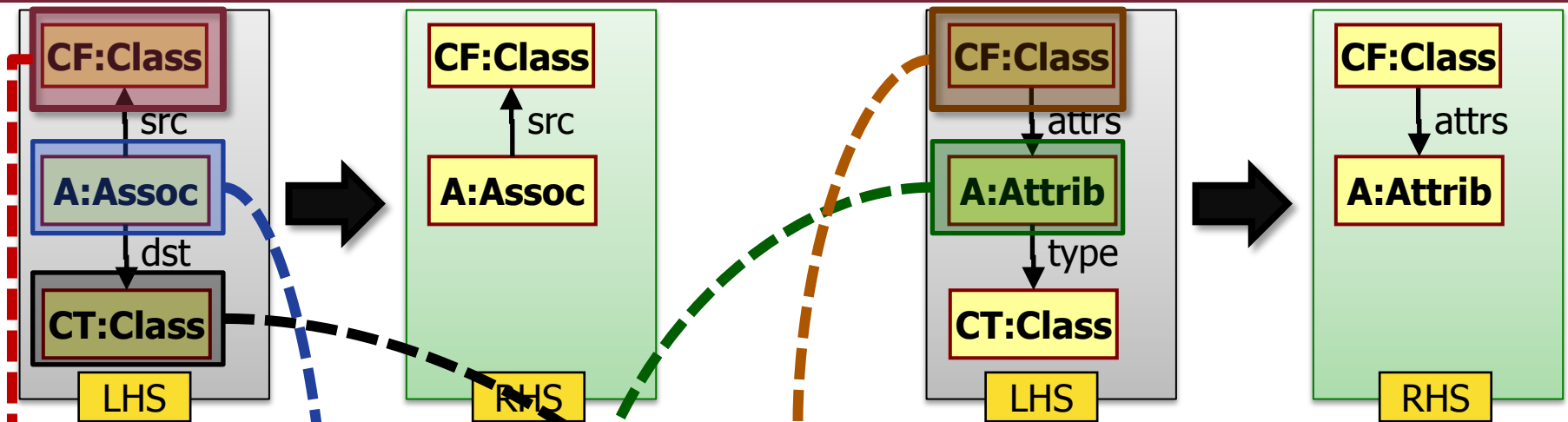

- Serial independence (two following rule applications)
 - Their order can be swapped without any effect on their final result

Serial independence

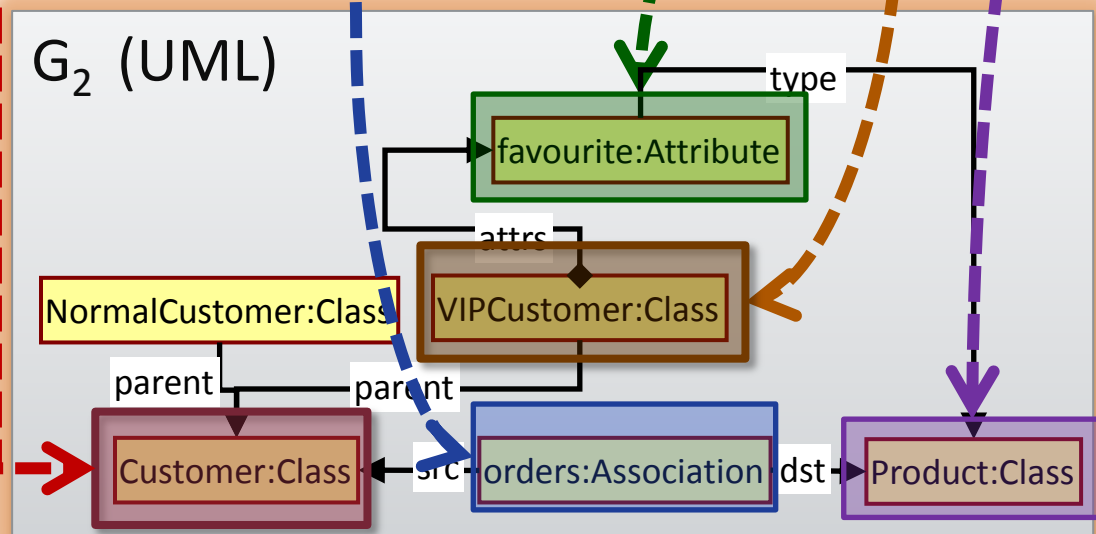
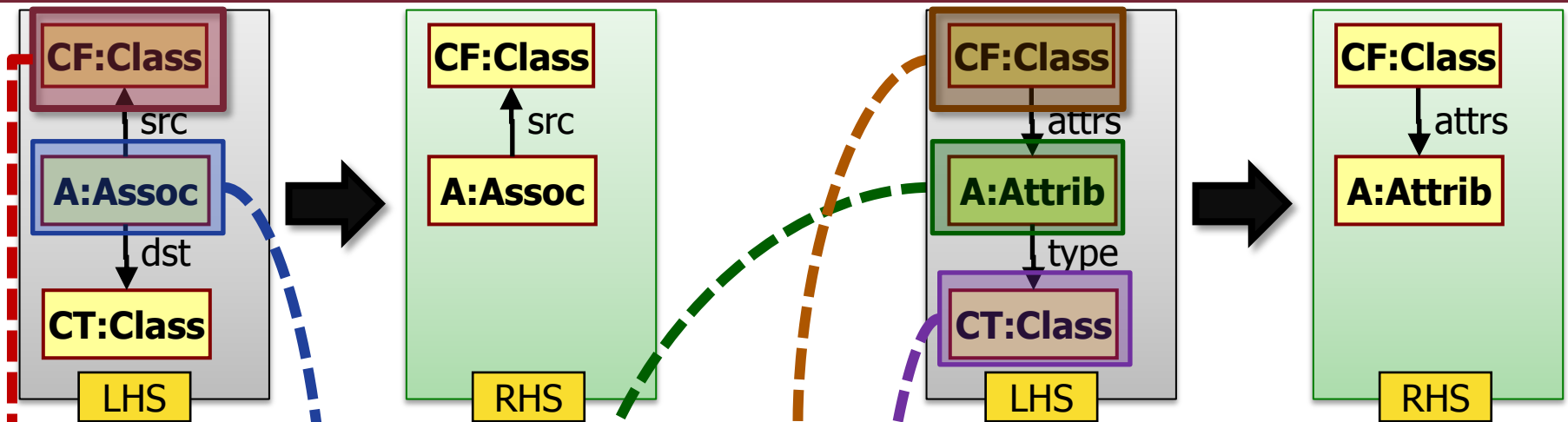

Serial independence
(two following rule applications)

- Their order can be swapped without any effect on their final result

Example

Kauzális függőség I.

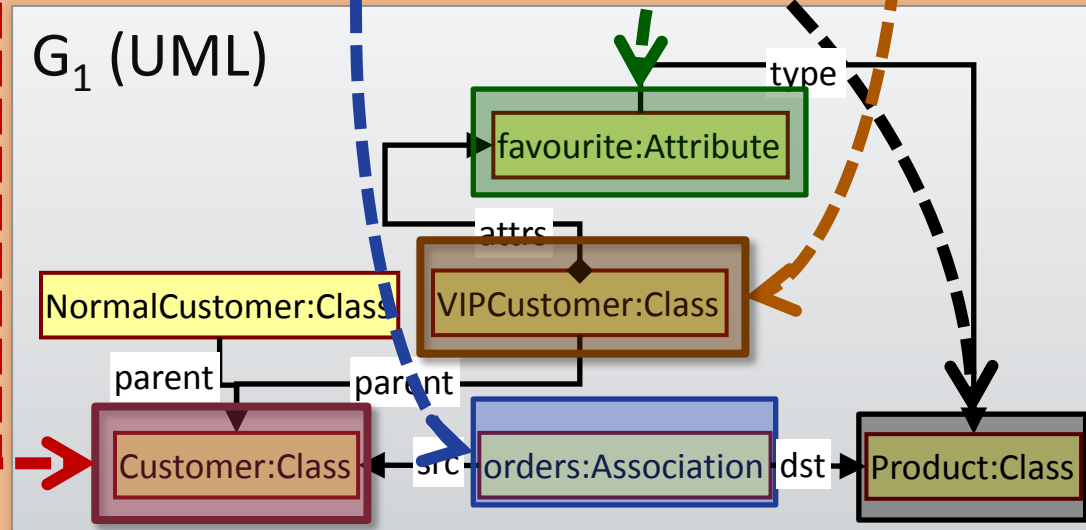
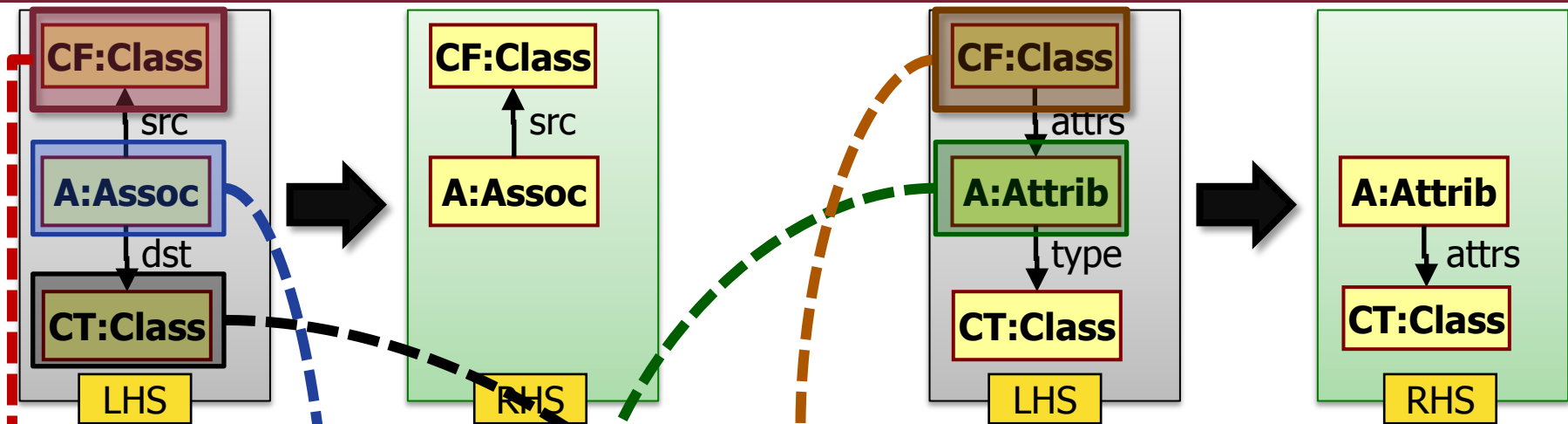

- **Serial independence**
(two following rule applications)
 - Their order can be swapped without any effect on their final result
- **Causally dependent**
(two following rule applications)
 - If they are not serial independent

Kauzális függőség II.

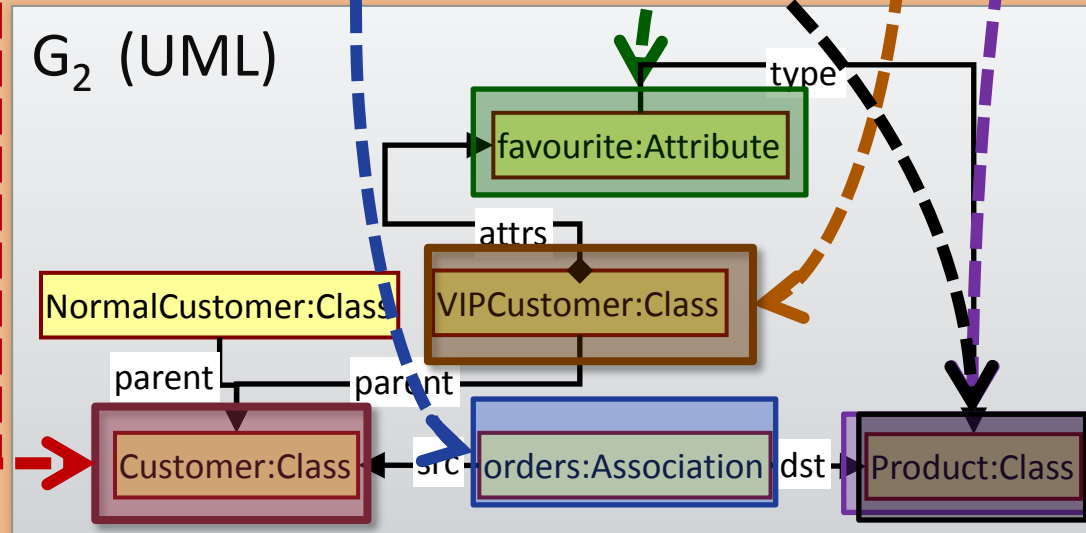
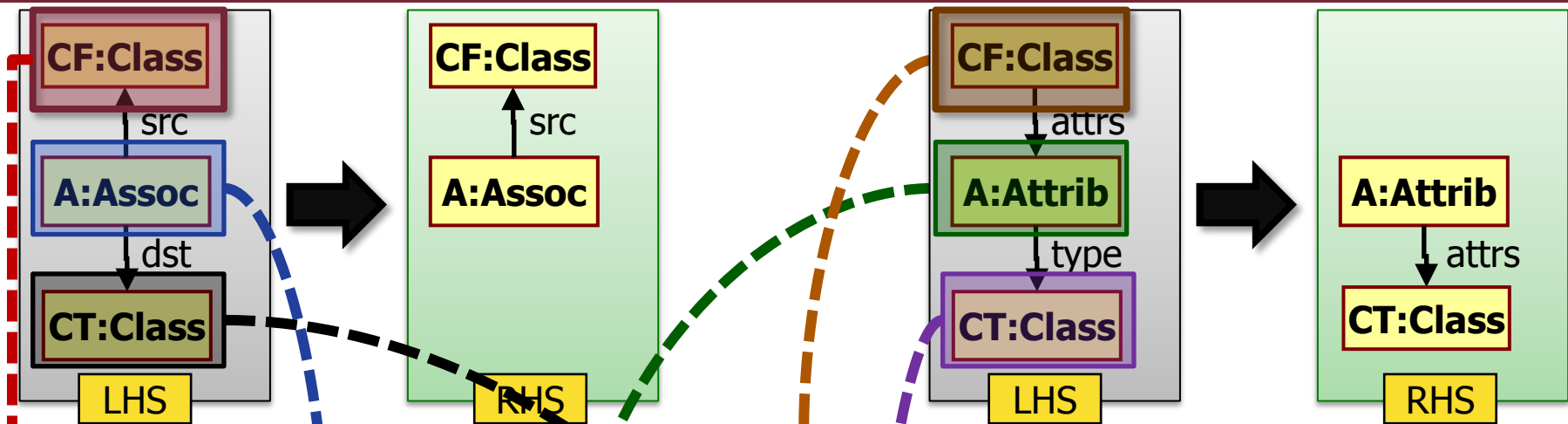

- **Serial independence**
(two following rule applications)
 - Their order can be swapped without any effect on their final result
- **Causally dependent**
(two following rule applications)
 - If they are not serial independent

➔ Example

Summary

- **Graphtransformation,**
as a modeltransformation paradigm
 - Rule and pattern based formal specification
 - Querying and manipulating graph based models
 - Intuitive graph based specification

- **Structure**

- LHS graph pattern: precondition
- RHS graph pattern: postcondition
- NAC: negative condition

- **Rule application**

- Graph pattern matching
- Deletion + Creation
- Dangling edges and injectivity
- Affect of multiple rule application (conflicts and causality)

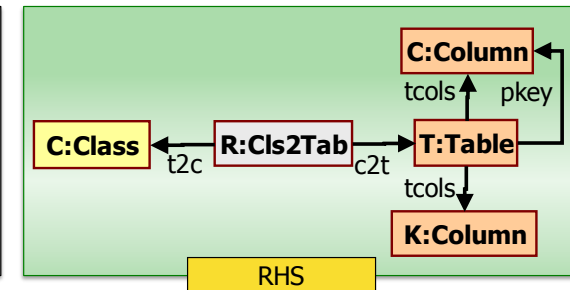
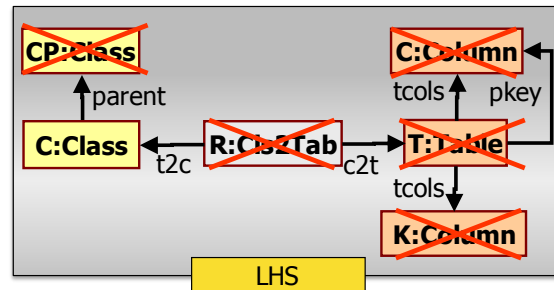

Model transformation approaches

MT: categories

- Model-to-Code (M2C)
 - Text generation
 - AST generation → special case of M2M
 - Ad-hoc, dedicated, template based, etc.
- Model-to-Model (M2M)
 - Between models
 - Intra-domain transformation
(e.g., simulation, refactoring, validation)
 - Inter-domain transformation
(PIM-to-PSM mapping, model analysis)
 - Bridging semantical gaps

Model Transformation approaches

- Direct Model Manipulation
- Relational
- Graph Transformation based
- Hybrid
- Other

Direct Model Manipulation

- Models stored in a Model Space
- Manipulation through API
- Queries hand coded

- Examples:
 - Base EMF
 - Jamda
 - SiTra

Relational Approaches

- Based on mathematical relations
 - Defined as constraints
 - Constraint logic programming
- Queries captured as constraints
- Model manipulation handled by *labeling*
- Fully declarative definition

- Example:
 - QVT

Graph Transformation based

- Model are graphs → use Graph Transformation
- Declarative definition
- Precise formal semantics
- Queries as graph patterns
- Model manipulation as graph transformation rules

- Examples:
 - AGG
 - GreAT
 - ATOM

Hybrid approaches

- Combines declarative and imperative definition
- "Developer friendly"
- Typically
 - Queries → declarative
 - Control Structure → imperative
- Complex language
- Largest transformations are using this approach

- Example:
 - ATL
 - Viatra2

Other - XSLT

- Models as XMI files
- Model Transformation as XSLT programs
- Hard to maintain
- XMI representations are
 - verbose
 - poor readability

Implementing a Graph Transformation Engine

Implementing GT engines

- Key elements
 - Model Store
 - Storing typed graphs
 - Support easy import and export
 - **Pattern Matching**
 - Find match for LHS
 - Model manipulation
 - Fast model manipulation
 - Rollback
 - Notification

Pattern matching techniques

■ Categories

- Interpreted: AGG (Tiger), VIATRA, MOLA, Groove, ATL
 - underlying PM engine
- Compiled: Fujaba, GReAT, PROGRES, Tiger
 - directly executed as a C or Java code (no PM engine)

■ Base algorithms

- Constraint satisfaction: AGG (Tiger)
 - variables + constraints
- **Local search**: Fujaba, GReAT, PROGRES, VIATRA, MOLA, Groove, Tiger (Compiled)
 - step-by-step extension of the matching
- **Incremental**: VIATRA, Tefkat
 - Updated cache mechanism

Constraint satisfaction based Pattern Matching

- **Realization:**
 - Nodes are handled as CSP variables
 - Constraints derived from edges
 - Type information as domain reduction
 - Traversal: backtracking algorithm
- **Pros:**
 - Adaptive algorithm
- **Contras:**
 - Handling large models
 - Scalability

Local Search based Pattern Matching

- **Method**
 - usually defined in design/compile time
 - simple search plan
 - hard wired precedence for constraint checking
(NAC, injectivity, attribute, etc.)
- **Good performance expected when:**
 - Small patterns, bound input parameters

Pattern Matching: Local Search

- PM can be the most time-consuming part
- Most implementations perform **local search**

- Examples: simplified Petri net firing

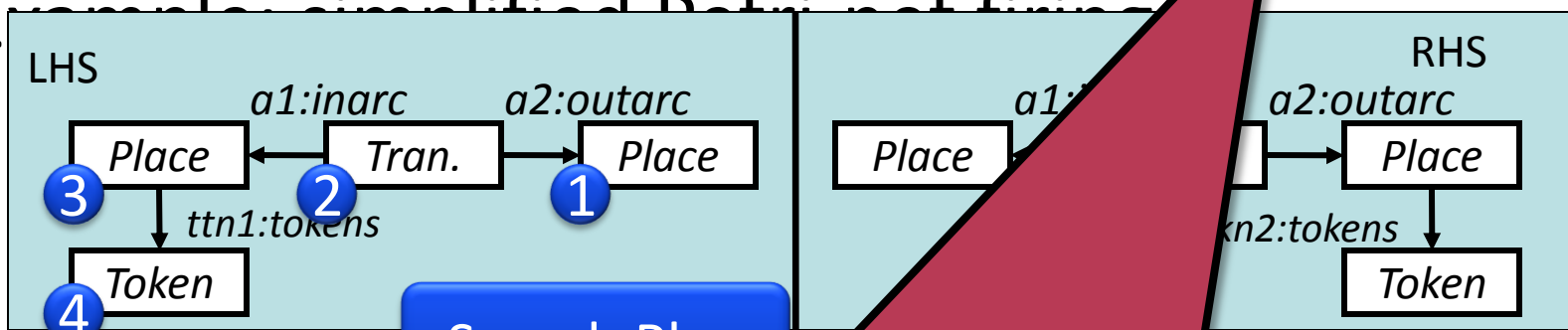

- Fujaba, GReAT, PROGRES, Groove, Tiger, GrGEN.NET...
- VIATRA2 also has a LS-based pattern matcher
- Good performance expected:
 - Small patterns, bound input parameters

1 2 3 4

Incremental Pattern Matching

- **Goal**
 - **Store matching sets**
 - Incremental update
 - Fast response
- **Good performance expected when:**
 - frequent pattern matching
 - Small updates
- **Possible application domain**
 - E.g. synchronization, constraints, model simulation, etc.
- **Example implementation (VIATRA): an adapted RETE algorithm**

Incremental Pattern Matching by RETE

- RETE net
 - node: (sub)pattern
 - edge: change propagation
- Demonstrating the principle
 - input: Petri-net
 - pattern: fireable transition
 - change: new transition

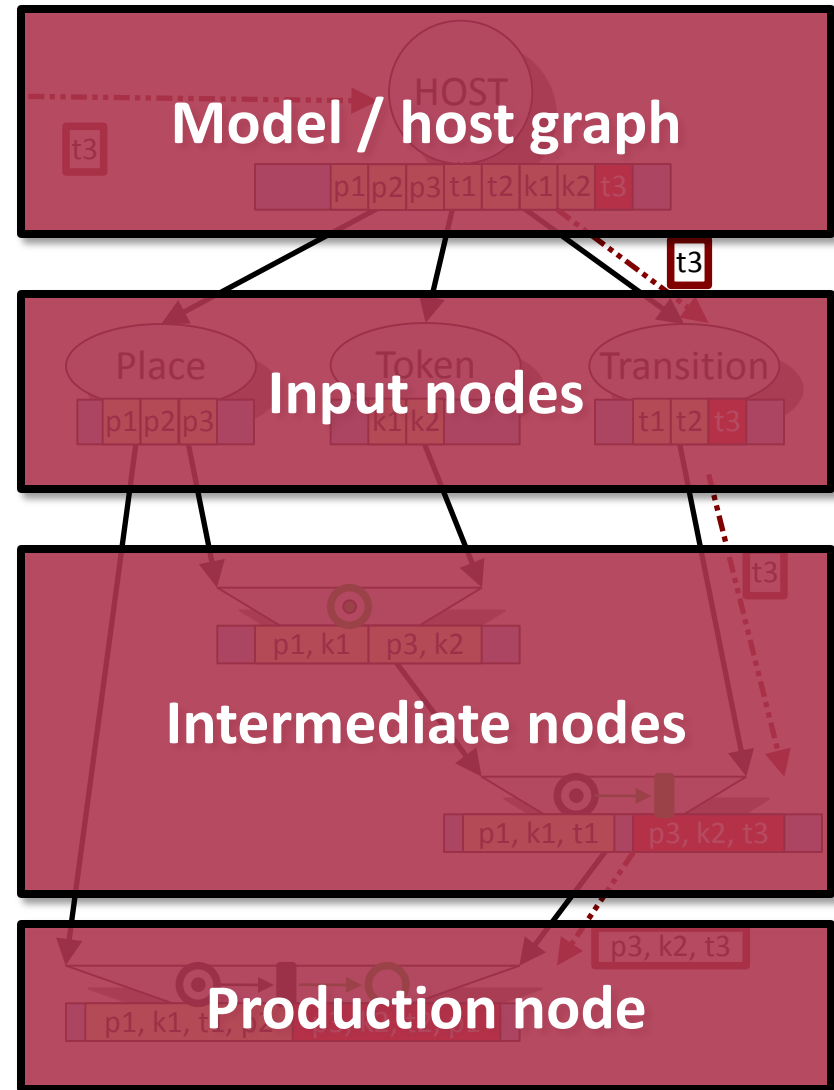
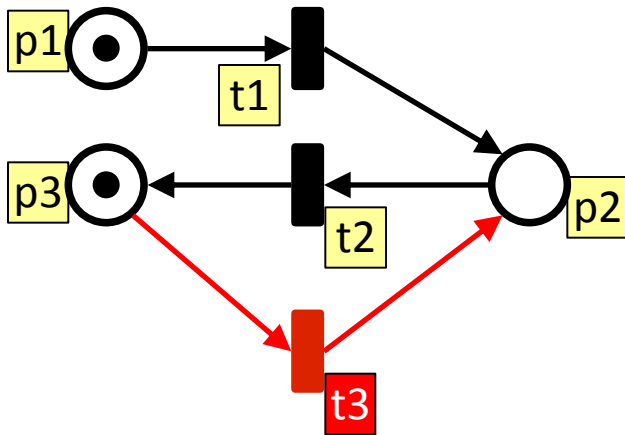

Hybrid pattern matching

- Combine local search-based and incremental pattern matching
- Motivation
 - Incremental PM is better for most cases, but...
 - Has memory overhead!
 - Has update overhead
 - → LS might be better in certain cases
 - Memory consumption (cache size)
 - Cache construction time penalty (overhead, simple navigation patterns)
 - Expensive updates (e.g., move operation)

Our research: Design and analysis of model transformation

